



## Sunshine Coast Regional District

## 2017 Trail Bridge Inspections – Final Report

Purchase Order # 3000710

Submitted December 1, 2017



**PARSONS**

Table of Contents

1	Executive Summary .....	1-1
2	Introduction .....	2-1
	2.1 Project Overview .....	2-1
	2.2 Inspection Procedures .....	2-1
	2.4 Scope of Inspections .....	2-2
3	Bridge Inspection Standards .....	3-1
	3.1 Introduction .....	3-1
	3.2 Condition Rating Scheme .....	3-1
	3.3 Priority of Recommendations .....	3-1
	3.4 Inspection Reports .....	3-1
	3.5 Load Rating Reports .....	3-1
	3.6 Structure Orientation .....	3-2
4	Inspection Results .....	4-1
	4.1 Development of Recommendations and Cost Estimates .....	4-1
	4.2 Comments Regarding Corrosion on Steel I-Beams .....	4-1
	4.3 Immediate Work .....	4-1
	4.4 Work to be carried out within 1 Year .....	4-2
	4.5 Work to be carried out within 3 Years .....	4-2
	4.6 Work to be carried out within 5 Years .....	4-3
	4.7 Bridge Ratings .....	4-4
	4.8 Remaining Lifespan of Bridges .....	4-5
	4.9 Summary .....	4-6
	4.10 Conclusion .....	4-6
5	Individual Bridge Inspection Reports, Load Ratings, and Photo Reports .....	5-1

## 1. EXECUTIVE SUMMARY

Comprehensive detailed inspections were undertaken by Parsons on 38 trail bridge structures along the Sunshine Coast, in September of 2017. Structures were comprised of timber or steel, with generally either lock-block foundations or founded on the soil below. Parsons was asked to return to the jobsite in November to inspect one new bridge as well. This bridge replaces another structure, therefore the total number remains at 38.

The deliverables for this project include this summary report, plus individual inspection reports, load-rating reports, and photo reports for each hiking trail structure along the Sunshine Coast.

Structure components were inspected and rated according to the 2010 Federal Government's Bridge Inspection Manual. Recommendations are made for repairs and maintenance on each structure over the next 5 years.

Of the 38 bridges inspected, 16 are "Very Good", 12 are "Good", 4 are "Fair", 5 are "Poor", and only 1 is "Very Poor / Critical."

The old Cliff Gilker Purple Bridge was "Very Poor" but it got replaced. Therefore there is only one "Critical" bridge is Vine Brook.

Vine Brook Bridge is in Critical Condition and SCRD should consider replacing it as soon as possible. Our load-rating calculations indicate that while it does meet strength criteria, it does not meet the deflection criteria as laid out in the Canadian Timber Design Manual. It would require the weight of negative two humans on the bridge in order to pass this requirement. We would recommend that it be closed to horses or ATVs and have a "Maximum 5 people" sign posted.

Work to be carried out with High Priority (1 year) totals \$49,000. This work is mostly relating to erosion gulleys that are developing around bridge piers/abutments.

Work to be carried out with Medium Priority (3 years) totals \$36,000. This work is mostly relating to monitoring deterioration and replacement of structural members.

Work to be carried out with Low Priority (5 years, or reassess in 5 years) totals \$16,000. This work includes painting, monitoring of conditions, or bridge replacements.

It was assumed that as bridges approach 40 years of age, 100% of them will be replaced. This might not be realistically true, as proper maintenance will improve the lifespan of structures. However, for long-term budgeting purposes, we have assumed that 100% of all bridges will need to be replaced. Our breakdown of full bridge replacement is: 5 years from now: \$85,000, 15 years from now: \$185,000, 25 years from now: \$255,000, and 40 years from now: \$205,000 for a total of: \$730,000 to replace all 38 bridges within the SCRD.

Thank you for giving us the opportunity to work along the Sunshine Coast. Please do not hesitate to contact me with any of your comments.

Cheers,



Grant Waldie, P.Eng., PE  
Project Manager – Bridge Rehabilitation  
Parsons Incorporated  
Grant.Waldie@parsons.com  
778-846-3385

## **2. INTRODUCTION**

### **2.1 Project Overview**

Parsons was retained by The Sunshine Coast Regional District to carry out inspections of 33 trail bridges along the Sunshine Coast, from Langdale to Ruby Lake. Structures were timber or steel I-beam bridges. More structures were found on site and a total of 38 were inspected.

The deliverables for this project include:

- Executive Summary
- Summary Report
- Individual Structure Inspection Report
- Individual Load-Rating Report
- Individual Structure Photo Report

### **2.2 Inspection Procedures**

Comprehensive detailed inspections were carried out from September 28-29, 2017. A second inspection took place on November 30 for the new Cliff Gilker Purple Bridge. Inspectors hiked to each bridge, while using a vehicle to drive along the Sunshine Coast Highway. Canada's Public Works and Government Services Bridge Inspection Manual was used as a template for our reports and rating scheme.

Prior to inspections, previous bridge photos were reviewed and bridge inspection forms were developed for each structure.

The field inspections were carried out by:

- Grant Waldie, P.Eng., PE – Inspection Team Leader
- Michael Li, M.A.Sc. – Inspection Team Member

The Load-Ratings were carried out by:

- Christian Hilbig, M.A.Sc. – Load-Rating Team Leader
- Keith Low, (P.Eng. Pending) – Load-Rating Team Member
- Michael Li, M.A.Sc. – Load-Rating Team Member
- Grant Waldie, P.Eng., PE – Load-Rating Team Member

A comprehensive detailed inspection was carried out on all components of each structure. Structural dimensions were measured in order to carry out load-rating calculations. General photos of the structure and watercourse were taken. Defects were documented and photographed. Each component of the structure was assigned a rating on a 1 to 5 scale (1 is very severe and 5 is as new) according to the Parks Canada Bridge Inspection Manual.

GPS coordinates were taken at each structure and recorded both on the device itself and written down on paper for backup.

### 2.3 Scope of Inspections

The number of structures in the scope within the original RFP was 33 bridges, however once we arrived on site we found a total of 38. Parsons has provided reports for these extra bridges at no extra cost.

The bridges have been categorized by “Zone” which lines up with the six maps that SCR D provided Parsons with.

The following structures were included the scope:

Zone 1
Overkill Bridge
Sakinaw 0
Sakinaw 1
Sakinaw 2
Klein Creek
Ruby Bluff Marsh
Vine Brook

Zone 2
Kleindale 1
Kleindale 2
Myers Creek
Lion's Sport Field

Zone 3
Circle Trail
Lone Owl
Noble Rd Lot X
Owl's Friend

Zone 4
Blackburn Trail
Clake Creek
Grey Trail
Red Back Stop
Blue Trail
Upper Waterfall
Blue Grey Trail
Coop Housing Trail
The Gorge
White Trail
Cliff Gilker Yellow Bridge
Roberts Creek
Robinson Trail
Lower Waterfall
Metcalf
Cal Bridge
Cliff Gilker Purple Bridge (New)

Zone 5
Chaster House
Sullivan Trail

Zone 6
Grantham Trail
Cedar Grove
Rock Face
Esperanza

### 3. **BRIDGE INSPECTION STANDARDS**

#### 3.1 **Introduction**

Comprehensive detailed inspections were carried out generally in accordance with the Parks Canada Bridge Inspection Manual (BIM 2010). All bridges were inspected by an experienced bridge inspector, Grant Waldie, P.Eng. Grant was assisted by Michael Li, M.A.Sc.

#### 3.2 **Condition Rating System**

The condition rating scale used for these inspections was based on the Parks Canada Bridge Inspection Manual (BIM). In general, condition ratings for the components of a structure are developed by considering both material and performance defects. Resulting ratings range from 1 to 5, with 1 representing the worst possible rating and 5 representing a component in as-new condition. This rating scheme can also be thought of in the following terms:

- 1 – Very Poor
- 2 – Poor
- 3 – Fair
- 4 – Good
- 5 – Very Good

#### 3.3 **Priority of Recommendations**

Instead of a coded priority system, we have chosen to simply use the “Low”, “Medium”, “High”, and “Immediate” to correspond to 5 years, 3 years, 1 year, and as-soon-as-possible for when repairs should be implemented.

#### 3.4 **Inspection Reports**

Included in our appendices are individual assessment reports for each bridge. The reports include the following:

- Description of bridge construction including type, material and dimensions
- Structural integrity of stringers, decking, sub deck and railing (cracks, fungus, rot)
- Condition of abutment and fasteners
- Deflection of bridge measured at center of deck
- Assessment of overall structural condition of the bridge
- Recommended weight and usage restriction for bridge
- Estimated life of bridge and Class D estimate to replace bridge in 2017 dollars
- Recommendation for signage for bridge
- Recommendation for immediate and future maintenance
- Class D cost estimate for immediate and future maintenance
- Supporting photographs
- Estimated remaining life of bridge assuming recommended maintenance is completed
- Threats to bridge (flooding, trees, bank erosion, over loading)

#### 3.5 **Load-Rating Reports**

Each structure has been individually load-rated. These reports come directly after the bridge inspection report, and before the photo report.

Three criteria were used for load-rating the report.

**Strength Criteria:** Standard timber and steel strength was used, in conjunction with factors of safety, to recommend a maximum load limit in terms of people, horses, and ATVs.

**Deflection Criteria:** The Timber Design Code's limit for deflection under live-loading was used to recommend a maximum load limit in terms of people, horses, and ATVs.

**Deck Area Criteria:** For most bridges, the square footage of the bridge is the limiting factor that will not physically allow enough people on the bridge to fail the deflection or strength criteria. We also maximized this rating out at 25 people, 1 horse, and 2 ATVs.

*\*For the Lions Bridge, a completely separate bridge report will be supplied to SCRD\**

When Deck Area Criteria was not the governing case, a recommendation for weight restriction signage was made.

### **3.6 Structure Orientation**

Global orientation to Magnetic North was used when referencing bridge geometry. This system is used when bridges do not follow a linear path, as is the case for the Sunshine Coast Trail Bridges.

## **4. INSPECTION RESULTS**

### **4.1 Development of Recommendations and Cost Estimates**

Care was taken in the development of recommended actions to optimize long term benefit in the management of these bridges. There are usually several repair options to consider in response to an observed defect and the optimal action depends heavily on the remaining lifespan of a structure and the rate of deterioration for a given component. The goal is to minimize long term costs using Life Cycle Cost Analysis principles in the development of recommendations.

In cases where deterioration of a component is observed but progressing very slowly and not causing safety risk, it is more cost-effective to wait until condition of the element is sufficiently poor to warrant the expense rather than to carry out expensive repairs prematurely.

#### **Construction Cost Estimates**

Class D cost estimates for bridge replacement cost and maintenance actions are based primarily on recent experience on other projects in BC and Alberta.

#### **Engineering Cost Estimates**

Due to the simple nature of the repairs we recommend, and the fact that SCR D has their own in-house carpenter who is able to carry out work, it is suspected that no engineering costs would be required to fix/replace bridges along the trail. However, if SCR D would like to engage Parsons for engineering work to design new structures, we would be able to provide a fee estimate.

### **4.2 Comments Regarding Corrosion on Steel I-Beams**

Corrosion exists on steel in three stages. The first stage is called the “visible” stage. This is characterized by being able to see a brownish hue to the steel. This patina of corrosion can act as a barrier to further corrosion and retard further deterioration. The second stage is called the “growing” stage. This is when pack-rust starts to form and the steel section increases in thickness. 5-10% of strength capacity is lost during this phase. The third and final stage is the “eating” stage. This is where the corrosion starts to reduce the thickness of the section, and strength capacity can be reduced to levels below intended design loads.

The bridges on the Sunshine Coast that have steel members are all experiencing corrosion to some extent. However, it is all in Stage 1. If Stage 3 ever is noticed, we would measure the section loss of the bottom flange, and then compared it to the design loads that the bridge is intended for. By calculating the new section modulus of the I-beam, and comparing it to a bending moment based on pedestrian traffic, we would be able to ascertain whether or not the I-beam should be strengthened. This, however, was never the case for bridges on the Sunshine Coast.

### **4.3 Immediate Work – Address As Soon As Possible**

Vine Brook Bridge is in Critical Condition and SCR D should consider replacing it as soon as possible. Our load-rating calculations indicate that while it does meet strength criteria, it does not meet the deflection criteria as laid out in the Canadian Timber Design Manual. It would require the weight of negative two humans on the bridge in order to pass this requirement. We would recommend that it be closed to horses or ATVs and have a “Maximum 5 people” sign posted.

**4.4 Work to be carried out within 1 Year – High Priority**

Zone	Bridge Name	Recommendations	Cost
1	Vine Brook	Replace main load carrying members of bridge	\$20,000
3	Lone Owl	Install load restriction sign	\$1,000
4	Lower Waterfall	Fill in erosion gulley underneath pier	\$5,000
		Fill in erosion gulley underneath pier. Shim up deck planks	\$5,000
4	Metcalfe	Relocate rocks from stream underneath eroded area on north embankment	\$2,000
4	Blue Trail	Install load restriction sign	\$1,000
4	Blue Grey Trail	Install load restriction sign	\$1,000
4	Cliff Gilker Purple (New)	Install two new vertical end posts at north abutment	\$2,000
4	The Gorge	Install load restriction sign	\$1,000
4	Roberts Creek	Install rip rap or gabian baskets at east abutment (see photo 27)	\$5,000
5	Sullivan Trail	Install load restriction sign	\$1,000
6	Cedar Grove	Monitor erosion, fill in with riprap, or remove tree	\$5,000
		Total:	\$49,000

**4.5 Work to be carried out within 3 Years – Medium Priority**

Zone	Bridge Name	Recommendations	Cost
1	Ruby Bluff Marsh	Replace deck planks	\$2,000
1	Vine Brook	Remove moss to prevent further deterioration	\$1,000
3	Circle Trail	Monitor erosion	N/A
		Remove old bridge	\$1,000
4	Upper Waterfall	Consider installing two more support at each corner of viewing platform	\$5,000
4	Cliff Gilker Yellow Bridge	Monitor beams	N/A
4	Lower Waterfall	Consider installing gabian baskets	\$15,000
4	Robinson Trail	Monitor erosion at base of tree	N/A
6	Grantham Trail	Monitor for erosion under bridge	N/A
6	Cedar Grove	Repair railing	\$2,000
6	Esperanza	Brace piers laterally with wires or timber braces	\$5,000
		Monitor rot on beam	N/A
		Brace piers laterally with wires or timber braces	\$5,000
		Monitor rot on beam	N/A
		Total:	\$36,000

**4.6 Work to be carried out within 5 Years – Low Priority**

Zone	Bridge Name	Recommendations	Cost
1	Ruby Bluff Marsh	Replace bridge	\$5,000
2	Lion's Sport Field	Repaint bridge	\$5,000
4	Grey Trail	Monitor and consider painting in 2019	\$5,000
4	Metcalfe	Monitor for erosion issues in the future	N/A
4	Cal Bridge	Monitor deterioration of members	N/A
6	Rock Face	Consider installing gravel or wood chips at south approach	\$1,000
		Total:	\$16,000

**4.7 Bridge Ratings**

Zone	Bridge Name	Rating
1	Overkill Bridge	Very Good
1	Sakinaw 0	Very Good
1	Sakinaw 1	Very Good
1	Sakinaw 2	Very Good
2	Kleindale 1	Very Good
2	Kleindale 2	Very Good
2	Myers Creek	Very Good
3	Circle Trail	Very Good
3	Lone Owl	Very Good
4	Blackburn Trail	Very Good
4	Clake Creek	Very Good
4	Cliff Gilker Purple Bridge (New)	Very Good
4	Grey Trail	Very Good
4	Red Back Stop	Very Good
4	Blue Trail	Very Good
5	Chaster House	Very Good
COUNT:		16
2	Lion's Sport Field	Good
3	Noble Rd Lot X	Good
3	Owl's Friend	Good
4	Upper Waterfall	Good
4	Blue Grey Trail	Good
4	Coop Housing Trail	Good
4	The Gorge	Good
4	White Trail	Good
5	Sullivan Trail	Good
6	Grantham Trail	Good
6	Cedar Grove	Good
6	Rock Face	Good
COUNT:		12

Zone	Bridge Name	Rating
1	Klein Creek	Fair
4	Cliff Gilker Yellow Bridge	Fair
4	Roberts Creek	Fair
4	Robinson Trail	Fair
COUNT:		4
1	Ruby Bluff Marsh	Poor
4	Lower Waterfall	Poor
4	Metcalfe	Poor
4	Cal Bridge	Poor
6	Esperanza	Poor
COUNT:		5
1	Vine Brook	Critical
COUNT:		2

**4.8 Remaining Lifespan of Bridges**

40 Years		
Zone	Bridge Name	Repacement Cost
1	Overkill Bridge	\$5,000
1	Sakinaw 0	\$5,000
1	Sakinaw 1	\$5,000
1	Sakinaw 2	\$5,000
3	Circle Trail	\$20,000
4	Blackburn Trail	\$30,000
4	Clake Creek	\$20,000
4	Cliff Gilker Purple (New)	\$30,000
4	Grey Trail	\$30,000
4	Red Back Stop	\$5,000
4	Upper Waterfall	\$20,000
5	Chaster House	\$30,000
	Total:	\$205,000

25 Years		
Zone	Bridge Name	Repacement Cost
1	Klein Creek	\$30,000
2	Kleindale 1	\$20,000
2	Kleindale 2	\$5,000
2	Myers Creek	\$20,000
2	Lion's Sport Field	\$30,000
3	Lone Owl	\$20,000
4	Blue Trail	\$5,000
4	Blue Grey Trail	\$20,000
4	Coop Housing Trail	\$30,000
4	The Gorge	\$30,000
4	White Trail	\$20,000
5	Sullivan Trail	\$20,000
6	Grantham Trail	\$5,000
	Total:	\$255,000

15 Years		
Zone	Bridge Name	Repacement Cost
3	Noble Rd Lot X	\$20,000
3	Owl's Friend	\$5,000
4	Cliff Gilker Yellow Bridge	\$20,000
4	Roberts Creek	\$30,000
4	Robinson Trail	\$30,000
4	Lower Waterfall	\$20,000
4	Metcalfe	\$20,000
6	Cedar Grove	\$20,000
6	Rock Face	\$20,000
	Total:	\$185,000

5 Years		
Zone	Bridge Name	Repacement Cost
1	Ruby Bluff Marsh	\$5,000
1	Vine Brook	\$20,000
4	Cal Bridge	\$30,000
6	Esperanza	\$30,000
	Total:	\$85,000

#### 4.9 Summary

The cost estimates for construction work are based on very similar projects that Parsons has assisted other clients with. These clients include BC Parks and Parks Canada on similar wilderness trails.

#### 4.10 Conclusion

Overall, the bridges along the Sunshine Coast are in Fair condition.

Vine Brook Bridge should be replaced as soon as possible, and various other erosion concerns should be addressed.

We first presented this report in DRAFT version, and now are presenting this report in FINAL format. However, if there are any more corrections or changes that SCR D would like us to make, we are able to amend our report. Please take the next few days to review and give us comment.

Thank you for giving us the opportunity to work on your bridges. Please do not hesitate to contact me with any of your comments.

Cheers,



Grant Waldie, P.Eng., PE  
Project Manager – Bridge Rehabilitation  
Parsons Incorporated  
Grant.Waldie@parsons.com  
778-846-3385

# **Appendix 1**

## **Zone 1 - Schedule B - Pender Bridge Assessment North**

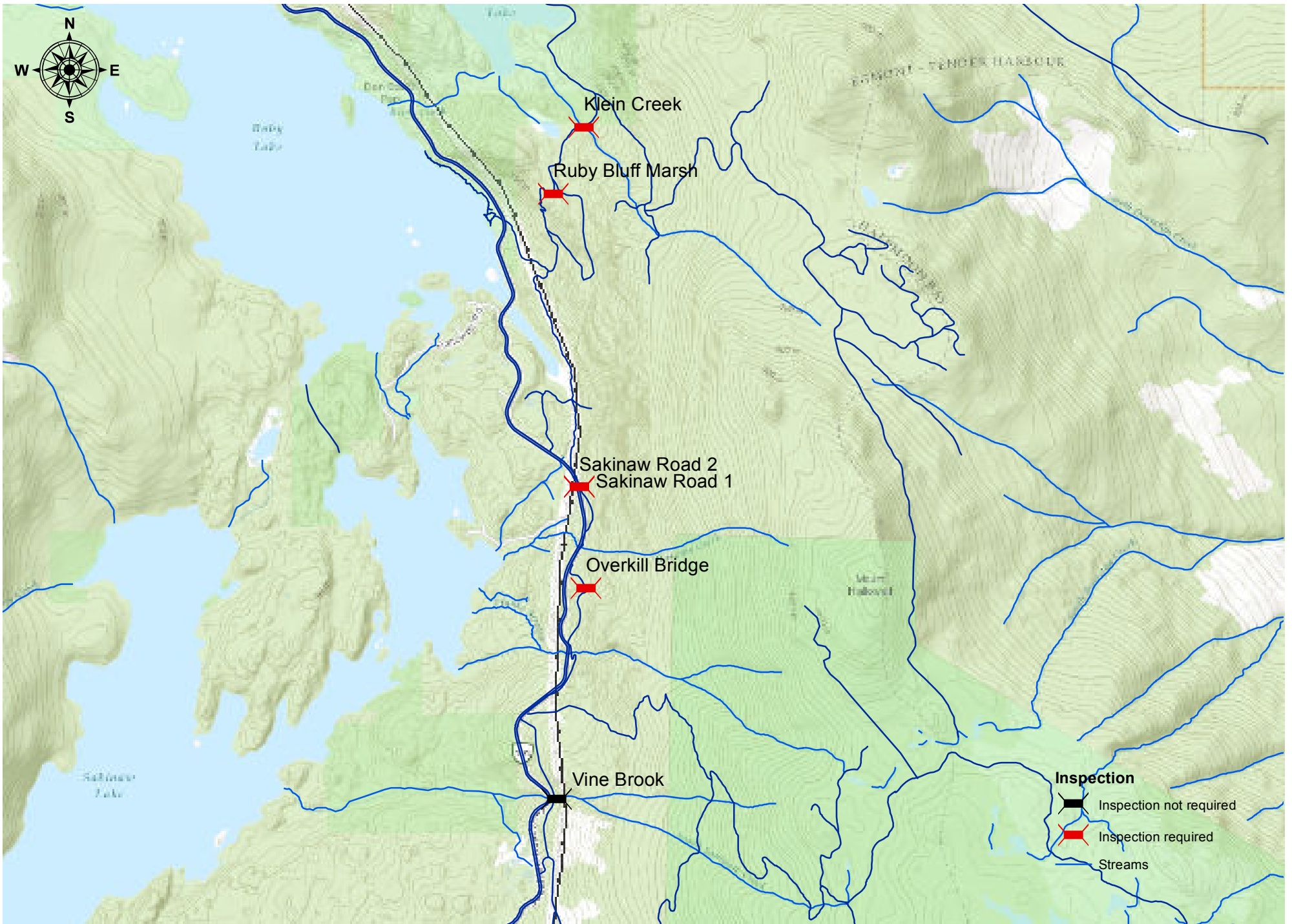

# Schedule B - Pender Bridge Assessment

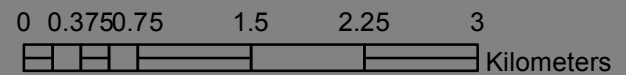



Sunshine Coast 2017  
Bridge Inspections



<b>Structure Name:</b>	Klein Creek	
<b>Remaining Lifespan (Years):</b>	25	
<b>Replacement Cost:</b>	\$30,000	
<b>Georeference:</b>	N 49°43'22" W 123°57'40"	
<b>Deflection at Centre (mm):</b>	0	
<b>Weight Usage Restriction:</b>	25 people, 1 horse, 2 ATVs	
<b>Date Inspected:</b>	Sept. 29, 2017	
<b>Inspected By:</b>	Grant Waldie, P. Eng., PE Michael Li, EIT	
<b>Weather:</b>	15°C, rainy	
<b>Overall Rating of Bridge</b>		<b>Structure Description</b>
FAIR		8x8m beam bridge with timber deck.

Element	Rating	Comments	Maintenance Recommendations	Estimated Cost	Priority
<b>Primary Components</b>					
Embankments	4				
Foundations	4				
Abutments	4				
Beams, Girders	4				
Deck	4				
<b>Secondary Components</b>					
Curbs	4				
Approaches	5				
<b>Auxiliary Components</b>					
Slope Protection	5				
Signs	4	No load restriction sign present			

## PROJECT

Sunshine Coast Trail Bridge Inspection Project

## DESIGNER

M.Li

## DATE

Oct 24th, 2017

## SUBJECT

Trail Bridge Load Rating

## CHECKER

G.Waldie

## DATE

Oct 25th, 2017

### Input Parameters

Bridge Name	<b>Klein Creek</b>
Number of Spans	1
Span Length (m)	8
Deck Width (mm)	8000
Deck Thickness (mm)	100
Number of Log Beams	18
Log Shape	Circular
Log Diameter (mm)	350
Single or Double Railing	N/A
Timber Weight (kN/m <sup>3</sup> )	6.0 (Douglas Fir)
Elastic Modulus of Timber	9000 (CSA-O86 T5.3.1C)

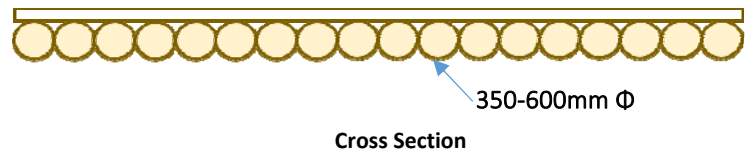

### Dead Load

Item	Railing	Deck	Log	Total
<b>w<sub>D</sub>(kN/m)</b>	0.00	4.80	10.39	15.19

Max. Bending Moment by DL  $M_D = wL^2/8 = 121.5 \text{ kN-m}$

Max. Deflection by DL  $\Delta_D = 5wL^4/384EI = 6.8 \text{ mm}$

### Capacity Check

Moment Resistance  $M_r = \Phi F_b S K_{z_b} K_L = 900.1 \text{ kN-m (CSA-O86 5.5.4.1)}$

Load combination for ULS:  $M_r = 1.25M_D + 1.5M_L$

Max. Bending Moment by LL  $M_L = 498.8 \text{ kN-m}$

Max. Live Load  $w_L = 62.3 \text{ kN/m}$

### Deflection Check

Load combination for SLS:  $\Delta_{lim} = 1.0\Delta_D + 1.0\Delta_L$

Max. Deflection  $\Delta_{lim} = L / 180 = 44.4 \text{ mm (CSA-O86 4.5.2)}$

Max. Deflection by LL  $\Delta_L = 37.7 \text{ mm}$

Max. Live Load  $w_L = 84.3 \text{ kN/m}$

### Deck Area Check

Total Deck Area  $A = 64.0 \text{ m}^2$

### Summary

	Capacity Check	Deflection Check	Deck Area Check
<b>Person</b>	> 25 people	> 25 people	> 25 people
<b>Horse</b>	> 1 horse	> 1 horse	> 1 horse
<b>ATV</b>	> 2 ATVs	> 2 ATVs	> 2 ATVs

### Conclusion:

The capacity of this bridge is governed by the bridge deck area. The maximum capacity of Klein Creek is: 25 people or 1 horse or 2 ATVs.

# Klein Creek

## Sunshine Coast Trail Bridge Inspections – 2017



P01 – South approach  
(DSCN9932.jpg)



P02 – North approach  
(DSCN9933.jpg)

**Klein Creek**  
Sunshine Coast Trail Bridge Inspections – 2017



P03 – Overall decking (looking east)  
(DSCN9934.jpg)



P04 – East railing  
(DSCN9935.jpg)

# Klein Creek

## Sunshine Coast Trail Bridge Inspections – 2017



P05 – Upstream (looking east)  
(DSCN9936.jpg)



P06 – East side of the bridge  
(DSCN9937.jpg)

**Klein Creek**  
Sunshine Coast Trail Bridge Inspections – 2017



P07 – South abutment  
(DSCN9939.jpg)



P08 – Under side of the bridge (looking at south abutment)  
(DSCN9940.jpg)

**Klein Creek**  
Sunshine Coast Trail Bridge Inspections – 2017



P09 – North abutment, gabion basket has fallen apart  
(DSCN9942.jpg)



P10 – Gabion basket at north abutment  
(DSCN9944.jpg)

# Klein Creek

## Sunshine Coast Trail Bridge Inspections – 2017



P11 – East side of the bridge  
(DSCN9948.jpg)



P12 – East side of the bridge (looking at north abutment)  
(DSCN9949.jpg)



## Sunshine Coast 2017 Bridge Inspections



<b>Structure Name:</b> Overkill Bridge	
<b>Parsons Waypoint #:</b> 291	
<b>Remaining Lifespan (Years):</b> 40	
<b>Replacement Cost:</b> \$5,000	
<b>Georeference:</b> N 49°41'47" W 123°57'42"	
<b>Deflection at Centre (mm):</b> 0	
<b>Weight Usage Restriction:</b> 25 people, 1 horse, 2 ATVs	
<b>Date Inspected:</b> Sept. 29, 2017	
<b>Inspected By:</b> Grant Waldie, P. Eng., PE Michael Li, EIT	
<b>Weather:</b> 15°C, rainy	
<b>Overall Rating of Bridge</b>	<b>Structure Description</b>
<b>VERY GOOD</b>	8.8x2.3m beam bridge with timber deck.

Element	Rating	Comments	Maintenance Recommendations	Estimated Cost	Priority
<b>Primary Components</b>					
Embankments	5				
Foundations	5				
Abutments	5				
Beams, Girders	5				
Deck	5				
<b>Secondary Components</b>					
Curbs	5				
Approaches	5				
Railings	5				
<b>Auxiliary Components</b>					
Slope Protection	5				
Signs	4	No load restriction sign present			

PROJECT	DESIGNER	DATE
Sunshine Coast Trail Bridge Inspection Project	M.Li	Oct 24th, 2017
SUBJECT	CHECKER	DATE
Trail Bridge Load Rating	G.Waldie	Oct 25th, 2017

## Input Parameters

Bridge Name	Overkill Bridge
Number of Spans	1
Span Length (m)	8.8
Deck Width (mm)	2300
Deck Thickness (mm)	50
Number of Log Beams	2
Log Shape	Circular
Log Diameter (mm)	550
Single or Double Railing	Single
Timber Weight (kN/m <sup>3</sup> )	6.0 (Douglas Fir)
Elastic Modulus of Timber	9000 (CSA-O86 T5.3.1C)

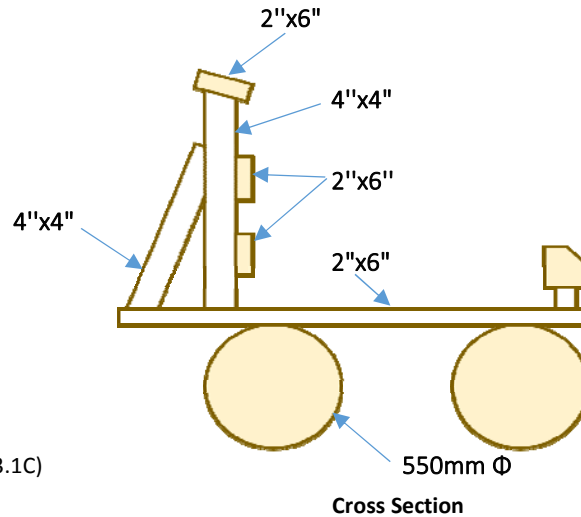

## Dead Load

Item	Railing	Deck	Log	Total
$w_D$ (kN/m)	0.25	0.69	2.85	3.79

Max. Bending Moment by DL  $M_D = wL^2/8 = 36.7$  kN-m

Max. Deflection by DL  $\Delta_D = 5wL^4/384EI = 3.7$  mm

## Capacity Check

Moment Resistance  $M_r = \Phi F_b S K_{zb} K_L = 388.1$  kN-m (CSA-O86 5.5.4.1)

Load combination for ULS:  $M_r = 1.25M_D + 1.5M_L$

Max. Bending Moment by LL  $M_L = 228.1$  kN-m

Max. Live Load  $w_L = 23.6$  kN/m

## Deflection Check

Load combination for SLS:  $\Delta_{lim} = 1.0\Delta_D + 1.0\Delta_L$

Max. Deflection  $\Delta_{lim} = L / 180 = 48.9$  mm (CSA-O86 4.5.2)

Max. Deflection by LL  $\Delta_L = 45.2$  mm

Max. Live Load  $w_L = 46.8$  kN/m

## Deck Area Check

Total Deck Area  $A = 20.2$  m<sup>2</sup>

## Summary

	Capacity Check	Deflection Check	Deck Area Check
Person	> 25 people	> 25 people	> 25 people
Horse	> 1 horse	> 1 horse	> 1 horse
ATV	> 2 ATVs	> 2 ATVs	> 2 ATVs

## Conclusion:

The capacity of this bridge is governed by the bridge deck area. The maximum capacity of Overkill Bridge is: 25 people or 1 horse or 2 ATVs.

# Overkill Bridge

## Sunshine Coast Trail Bridge Inspections – 2017



P01 – North approach  
(DSCN9870.jpg)



P02 – West railing  
(DSCN9871.jpg)

# Overkill Bridge

## Sunshine Coast Trail Bridge Inspections – 2017



P03 – Overall decking  
(DSCN9872.jpg)



P04 – South approach  
(DSCN9873.jpg)

# Overkill Bridge

## Sunshine Coast Trail Bridge Inspections – 2017



P05 – West side of the bridge  
(DSCN9876.jpg)



P06 – South abutment  
(DSCN9877.jpg)

# Overkill Bridge

## Sunshine Coast Trail Bridge Inspections – 2017



P07 – Under side of the bridge  
(DSCN9878.jpg)



P08 – Under side of the bridge (looking at north abutment)  
(DSCN9879.jpg)

# Overkill Bridge

## Sunshine Coast Trail Bridge Inspections – 2017



P09 – East side of the bridge  
(DSCN9880.jpg)



P10 – North abutment  
(DSCN9881.jpg)

**Overkill Bridge**  
Sunshine Coast Trail Bridge Inspections – 2017



P11 – East side of the bridge (detail view of the log)  
(DSCN9882.jpg)



Sunshine Coast 2017  
Bridge Inspections



<b>Structure Name:</b>	Ruby Bluff Marsh	
<b>Parsons Waypoint #:</b>	308	
<b>Remaining Lifespan (Years):</b>	5	
<b>Replacement Cost:</b>	\$5,000	
<b>Georeference:</b>	N 49°43'07" W 123°57'51"	
<b>Deflection at Centre (mm):</b>	0	
<b>Weight Usage Restriction:</b>	14 people, 1 horse, 1 ATV	
<b>Date Inspected:</b>	Sept. 29, 2017	
<b>Inspected By:</b>	Grant Waldie, P. Eng., PE Michael Li, EIT	
<b>Weather:</b>	15°C, rainy	
<b>Overall Rating of Bridge</b>		<b>Structure Description</b>
POOR		2.8x2.5m beam bridge with timber deck.

Element	Rating	Comments	Maintenance Recommendations	Estimated Cost	Priority
<b>Primary Components</b>					
Embankments	4				
Foundations	4				
Abutments	4				
Beams, Girders	2	Logs are collapsing onto rocks below bridge	Replace bridge	\$5,000	Low
Deck	2	Deck planks are deteriorating	Replace deck planks	\$2,000	Medium
<b>Secondary Components</b>					
Approaches	5				
<b>Auxiliary Components</b>					
Slope Protection	5				
Signs	4	No load restriction sign present			

PROJECT	DESIGNER	DATE
Sunshine Coast Trail Bridge Inspection Project	M.Li	Oct 24th, 2017
SUBJECT	CHECKER	DATE
Trail Bridge Load Rating	G.Waldie	Oct 25th, 2017

## Input Parameters

Bridge Name	Ruby Bluff Marsh
Number of Spans	1
Span Length (m)	2.8
Deck Width (mm)	2500
Deck Thickness (mm)	50
Number of Log Beams	3
Log Shape	Circular
Log Diameter (mm)	200
Single or Double Railing	Single
Timber Weight (kN/m <sup>3</sup> )	5.0 (Cedar)
Elastic Modulus of Timber	9000 (CSA-O86 T5.3.1C)

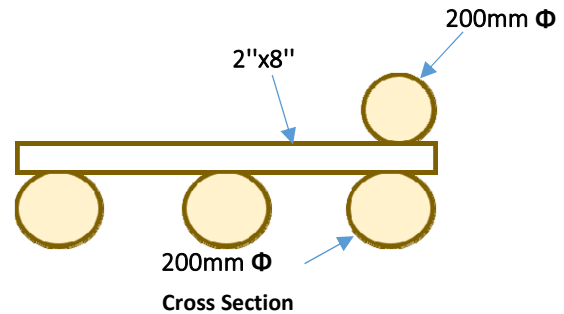

## Dead Load

Item	Railing	Deck	Log	Total
$w_D$ (kN/m)	0.10	0.63	0.47	1.20

Max. Bending Moment by DL  $M_D = wL^2/8 = 1.2 \text{ kN-m}$

Max. Deflection by DL  $\Delta_D = 5wL^4/384EI = 0.5 \text{ mm}$

## Capacity Check

Moment Resistance  $M_r = \Phi F_b S K_{zb} K_L = 27.99 \text{ kN-m}$  (CSA-O86 5.5.4.1)

Load combination for ULS:  $M_r = 1.25M_D + 1.5M_L$

Max. Bending Moment by LL  $M_L = 17.7 \text{ kN-m}$

Max. Live Load  $w_L = 18.0 \text{ kN/m}$

## Deflection Check

Load combination for SLS:  $\Delta_{lim} = 1.0\Delta_D + 1.0\Delta_L$

Max. Deflection  $\Delta_{lim} = L/180 = 15.6 \text{ mm}$  (CSA-O86 4.5.2)

Max. Deflection by LL  $\Delta_L = 15.1 \text{ mm}$

Max. Live Load  $w_L = 40.0 \text{ kN/m}$

## Deck Area Check

Total Deck Area  $A = 7.0 \text{ m}^2$

## Summary

	Capacity Check	Deflection Check	Deck Area Check
Person	> 14 people	> 14 people	14 people
Horse	> 1 horse	> 1 horse	1 horse
ATV	> 1 ATV	> 1 ATV	1 ATV

## Conclusion:

The capacity of this bridge is governed by the bridge deck area. The maximum capacity of Ruby Bluff Marsh is: 14 people or 1 horse or 1 ATV.

**Ruby Bluff Marsh**  
Sunshine Coast Trail Bridge Inspections – 2017



P01 – South approach  
(DSCN9924.jpg)



P02 – Overall decking, deck is in poor condition  
(DSCN9925.jpg)

# Ruby Bluff Marsh

## Sunshine Coast Trail Bridge Inspections – 2017



P03 – North approach  
(DSCN9926.jpg)



P04 – West side of the bridge  
(DSCN9927.jpg)

# Ruby Bluff Marsh

## Sunshine Coast Trail Bridge Inspections – 2017



P05 – West side of the bridge, the entire deck is collapsing on rocks below it (DSCN9929.jpg)



Sunshine Coast 2017  
Bridge Inspections



<b>Structure Name:</b>	Sakinaw 0	
<b>Parsons Waypoint #:</b>	294	
<b>Remaining Lifespan (Years):</b>	40	
<b>Replacement Cost:</b>	\$5,000	
<b>Georeference:</b>	N 49°42'04" W 123°57'41"	
<b>Deflection at Centre (mm):</b>	0	
<b>Weight Usage Restriction:</b>	19 people, 1 horse, 2 ATVs	
<b>Date Inspected:</b>	Sept. 29, 2017	
<b>Inspected By:</b>	Grant Waldie, P. Eng., PE Michael Li, EIT	
<b>Weather:</b>	15°C, rainy	
<b>Overall Rating of Bridge</b>		<b>Structure Description</b>
VERY GOOD		4.2x2.3m beam bridge with timber deck.

Element	Rating	Comments	Maintenance Recommendations	Estimated Cost	Priority
<b>Primary Components</b>					
Embankments	5				
Foundations	5				
Abutments	5				
Beams, Girders	5				
Deck	5				
<b>Secondary Components</b>					
Curbs	5				
Approaches	5				
Railings	5				
<b>Auxiliary Components</b>					
Slope Protection	5				
Signs	4	No load restriction sign present			

PROJECT	DESIGNER	DATE
Sunshine Coast Trail Bridge Inspection Project	M.Li	Oct 24th, 2017
SUBJECT	CHECKER	DATE
Trail Bridge Load Rating	G.Waldie	Oct 25th, 2017

## Input Parameters

Bridge Name	Sakinaw 0
Number of Spans	1
Span Length (m)	4.2
Deck Width (mm)	2300
Deck Thickness (mm)	50
Number of Log Beams	3
Log Shape	Circular
Log Diameter (mm)	200
Single or Double Railing	Single
Timber Weight (kN/m <sup>3</sup> )	5.0 (Cedar)
Elastic Modulus of Timber	9000 (CSA-O86 T5.3.1C)

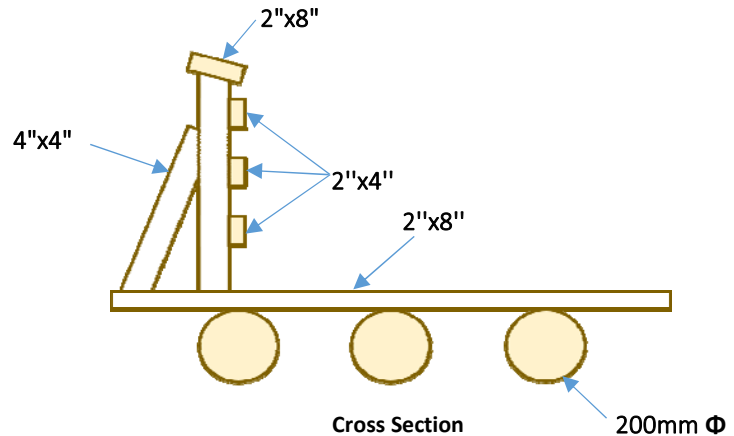

## Dead Load

Item	Railing	Deck	Log	Total
$w_D$ (kN/m)	0.00	0.58	0.47	1.05

Max. Bending Moment by DL  $M_D = wL^2/8 = 2.3 \text{ kN-m}$

Max. Deflection by DL  $\Delta_D = 5wL^4/384EI = 2.0 \text{ mm}$

## Capacity Check

Moment Resistance  $M_r = \Phi F_b S K_{zb} K_L = 27.99 \text{ kN-m}$  (CSA-O86 5.5.4.1)

Load combination for ULS:  $M_r = 1.25M_D + 1.5M_L$

Max. Bending Moment by LL  $M_L = 16.7 \text{ kN-m}$

Max. Live Load  $w_L = 7.6 \text{ kN/m}$

## Deflection Check

Load combination for SLS:  $\Delta_{lim} = 1.0\Delta_D + 1.0\Delta_L$

Max. Deflection  $\Delta_{lim} = L/180 = 23.3 \text{ mm}$  (CSA-O86 4.5.2)

Max. Deflection by LL  $\Delta_L = 21.3 \text{ mm}$

Max. Live Load  $w_L = 11.2 \text{ kN/m}$

## Deck Area Check

Total Deck Area  $A = 9.7 \text{ m}^2$

## Summary

	Capacity Check	Deflection Check	Deck Area Check
Person	> 19 people	> 19 people	19 people
Horse	> 1 horse	> 1 horse	1 horse
ATV	> 2 ATVs	> 2 ATVs	2 ATVs

## Conclusion:

The capacity of this bridge is governed by the bridge deck area. The maximum capacity of Sakinaw 0 is: 19 people or 1 horse or 2 ATVs.

**Sakinaw 0**  
Sunshine Coast Trail Bridge Inspections – 2017



P01 – North approach  
(DSCN9905.jpg)



P02 – West railing  
(DSCN9906.jpg)

**Sakinaw 0**  
Sunshine Coast Trail Bridge Inspections – 2017



P03 – Overall decking, suggest adding anti-slip pad  
(DSCN9907.jpg)



P04 – South approach  
(DSCN9908.jpg)

**Sakinaw 0**  
Sunshine Coast Trail Bridge Inspections – 2017



P05 – East side of the bridge  
(DSCN9910.jpg)



P06 – South abutment  
(DSCN9911.jpg)

**Sakinaw 0**  
Sunshine Coast Trail Bridge Inspections – 2017



P07 – North abutment  
(DSCN9912.jpg)



P08 – Under side of the bridge  
(DSCN9913.jpg)



Sunshine Coast 2017  
Bridge Inspections



<b>Structure Name:</b>	Sakinaw 1	
<b>Parsons Waypoint #:</b>	293	
<b>Remaining Lifespan (Years):</b>	40	
<b>Replacement Cost:</b>	\$5,000	
<b>Georeference:</b>	N 49°42'04" W 123°57'42"	
<b>Deflection at Centre (mm):</b>	0	
<b>Weight Usage Restriction:</b>	8 people, 1 horse, 1 ATV	
<b>Date Inspected:</b>	Sept. 29, 2017	
<b>Inspected By:</b>	Grant Waldie, P. Eng., PE Michael Li, EIT	
<b>Weather:</b>	15°C, rainy	
<b>Overall Rating of Bridge</b>		<b>Structure Description</b>
VERY GOOD		1.8x2.3m beam bridge with timber deck.

Element	Rating	Comments	Maintenance Recommendations	Estimated Cost	Priority
<b>Primary Components</b>					
Embankments	5				
Foundations	5				
Abutments	5				
Beams, Girders	5				
Deck	5				
<b>Secondary Components</b>					
Curbs	5				
Approaches	5				
<b>Auxiliary Components</b>					
Slope Protection	5				
Signs	4	No load restriction sign present			

PROJECT	DESIGNER	DATE
Sunshine Coast Trail Bridge Inspection Project	M.Li	Oct 24th, 2017
SUBJECT	CHECKER	DATE
Trail Bridge Load Rating	G.Waldie	Oct 25th, 2017

## Input Parameters

Bridge Name	Sakinaw 1		
Number of Spans	1		
Span Length (m)	1.8		
Deck Width (mm)	2300		
Deck Thickness (mm)	50		
Number of Log Beams	4		
Log Shape	Rectangul:		
Log Size b*d (mm*mm)	100	X	200
Single or Double Railing	Single		
Timber Weight (kN/m <sup>3</sup> )	5.0	(Cedar)	
Elastic Modulus of Timber	9000	(CSA-O86 T5.3.1C)	

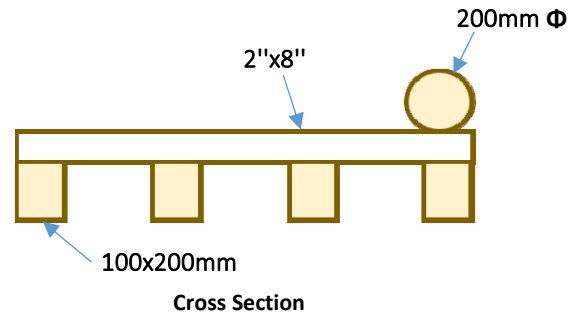

## Dead Load

Item	Railing	Deck	Log	Total
<b>w<sub>D</sub>(kN/m)</b>	0.10	0.58	0.40	1.08

Max. Bending Moment by DL  $M_D = wL^2/8 = 0.4 \text{ kN-m}$

Max. Deflection by DL  $\Delta_D = 5wL^4/384EI = 0.1 \text{ mm}$

## Capacity Check

Moment Resistance  $M_r = \Phi F_b S K_{zb} K_L = 31.68 \text{ kN-m}$  (CSA-O86 5.5.4.1)

Load combination for ULS:  $M_r = 1.25M_D + 1.5M_L$

Max. Bending Moment by LL  $M_L = 20.8 \text{ kN-m}$

Max. Live Load  $w_L = 51.3 \text{ kN/m}$

## Deflection Check

Load combination for SLS:  $\Delta_{lim} = 1.0\Delta_D + 1.0\Delta_L$

Max. Deflection  $\Delta_{lim} = L / 180 = 10.0 \text{ mm}$  (CSA-O86 4.5.2)

Max. Deflection by LL  $\Delta_L = 9.9 \text{ mm}$

Max. Live Load  $w_L = 174.5 \text{ kN/m}$

## Deck Area Check

Total Deck Area  $A = 4.1 \text{ m}^2$

## Summary

	Capacity Check	Deflection Check	Deck Area Check
<b>Person</b>	> 8 people	> 8 people	8 people
<b>Horse</b>	> 1 horse	> 1 horse	1 horse
<b>ATV</b>	> 1 ATV	> 1 ATV	1 ATV

## Conclusion:

The capacity of this bridge is governed by the bridge deck area. The maximum capacity of Sakinaw 1 is: 8 people or 1 horse or 1 ATV.

**Sakinaw 1**  
Sunshine Coast Trail Bridge Inspections – 2017



P01 – South approach  
(DSCN9894.jpg)



P02 – West railing  
(DSCN9895.jpg)

# Sakinaw 1

## Sunshine Coast Trail Bridge Inspections – 2017



P03 – Overall decking, suggest adding anti-slip pad  
(DSCN9896.jpg)



P04 – North side of the bridge  
(DSCN9898.jpg)

**Sakinaw 1**  
Sunshine Coast Trail Bridge Inspections – 2017



P05 – East side of the bridge  
(DSCN9899.jpg)



P06 – West side of the bridge  
(DSCN9900.jpg)

**Sakinaw 1**  
Sunshine Coast Trail Bridge Inspections – 2017



P07 – North abutment  
(DSCN9901.jpg)



P08 – South abutment  
(DSCN9902.jpg)

**Sakinaw 1**  
Sunshine Coast Trail Bridge Inspections – 2017



P09 – Under side of the bridge  
(DSCN9903.jpg)



Sunshine Coast 2017  
Bridge Inspections



<b>Structure Name:</b>	Sakinaw 2	
<b>Parsons Waypoint #:</b>	292	
<b>Remaining Lifespan (Years):</b>	40	
<b>Replacement Cost:</b>	\$5,000	
<b>Georeference:</b>	N 49°42'05" W 123°57'42"	
<b>Deflection at Centre (mm):</b>	0	
<b>Weight Usage Restriction:</b>	8 people, 1 horse, 1 ATV	
<b>Date Inspected:</b>	Sept. 29, 2017	
<b>Inspected By:</b>	Grant Waldie, P. Eng., PE Michael Li, EIT	
<b>Weather:</b>	15°C, rainy	
<b>Overall Rating of Bridge</b>		<b>Structure Description</b>
VERY GOOD		1.8x2.3m beam bridge with timber deck.

Element	Rating	Comments	Maintenance Recommendations	Estimated Cost	Priority
<b>Primary Components</b>					
Embankments	5				
Foundations	5				
Abutments	5				
Beams, Girders	5				
Deck	5				
<b>Secondary Components</b>					
Curbs	5				
Approaches	5				
<b>Auxiliary Components</b>					
Slope Protection	5				
Signs	4	No load restriction sign present			

PROJECT	DESIGNER	DATE
Sunshine Coast Trail Bridge Inspection Project	M.Li	Oct 24th, 2017
SUBJECT	CHECKER	DATE
Trail Bridge Load Rating	G.Waldie	Oct 25th, 2017

## Input Parameters

Bridge Name	Sakinaw 2		
Number of Spans	1		
Span Length (m)	1.8		
Deck Width (mm)	2300		
Deck Thickness (mm)	50		
Number of Log Beams	4		
Log Shape	Rectangul:		
Log Size b*d (mm*mm)	100	X	200
Single or Double Railing	Single		
Timber Weight (kN/m <sup>3</sup> )	5.0	(Cedar)	
Elastic Modulus of Timber	9000	(CSA-O86 T5.3.1C)	

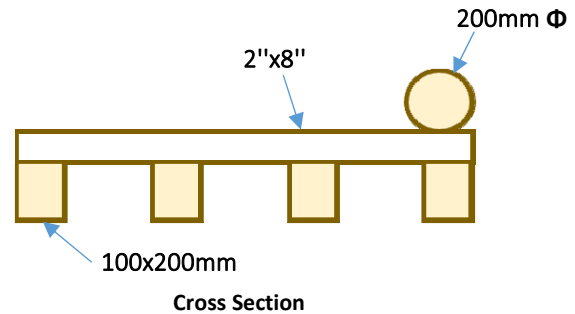

## Dead Load

Item	Railing	Deck	Log	Total
$w_D$ (kN/m)	0.10	0.58	0.40	1.08

Max. Bending Moment by DL  $M_D = wL^2/8 = 0.4 \text{ kN-m}$

Max. Deflection by DL  $\Delta_D = 5wL^4/384EI = 0.1 \text{ mm}$

## Capacity Check

Moment Resistance  $M_r = \Phi F_b S K_{zb} K_L = 31.68 \text{ kN-m}$  (CSA-O86 5.5.4.1)

Load combination for ULS:  $M_r = 1.25M_D + 1.5M_L$

Max. Bending Moment by LL  $M_L = 20.8 \text{ kN-m}$

Max. Live Load  $w_L = 51.3 \text{ kN/m}$

## Deflection Check

Load combination for SLS:  $\Delta_{lim} = 1.0\Delta_D + 1.0\Delta_L$

Max. Deflection  $\Delta_{lim} = L / 180 = 10.0 \text{ mm}$  (CSA-O86 4.5.2)

Max. Deflection by LL  $\Delta_L = 9.9 \text{ mm}$

Max. Live Load  $w_L = 174.5 \text{ kN/m}$

## Deck Area Check

Total Deck Area  $A = 4.1 \text{ m}^2$

## Summary

	Capacity Check	Deflection Check	Deck Area Check
Person	> 8 people	> 8 people	8 people
Horse	> 1 horse	> 1 horse	1 horse
ATV	> 1 ATV	> 1 ATV	1 ATV

## Conclusion:

The capacity of this bridge is governed by the bridge deck area. The maximum capacity of Sakinaw 2 is: 8 people or 1 horse or 1 ATV.

## Sakinaw 2

### Sunshine Coast Trail Bridge Inspections – 2017



P01 – South approach, suggest adding anti-slip pad  
(DSCN9884.jpg)



P02 – West railing  
(DSCN9885.jpg)

## Sakinaw 2

### Sunshine Coast Trail Bridge Inspections – 2017



P03 – North approach  
(DSCN9887.jpg)



P04 – Downhill (looking west)  
(DSCN9888.jpg)

## Sakinaw 2

### Sunshine Coast Trail Bridge Inspections – 2017



P05 – West side of the bridge  
(DSCN9889.jpg)



P06 – Under side of the bridge  
(DSCN9890.jpg)

**Sakinaw 2**  
Sunshine Coast Trail Bridge Inspections – 2017

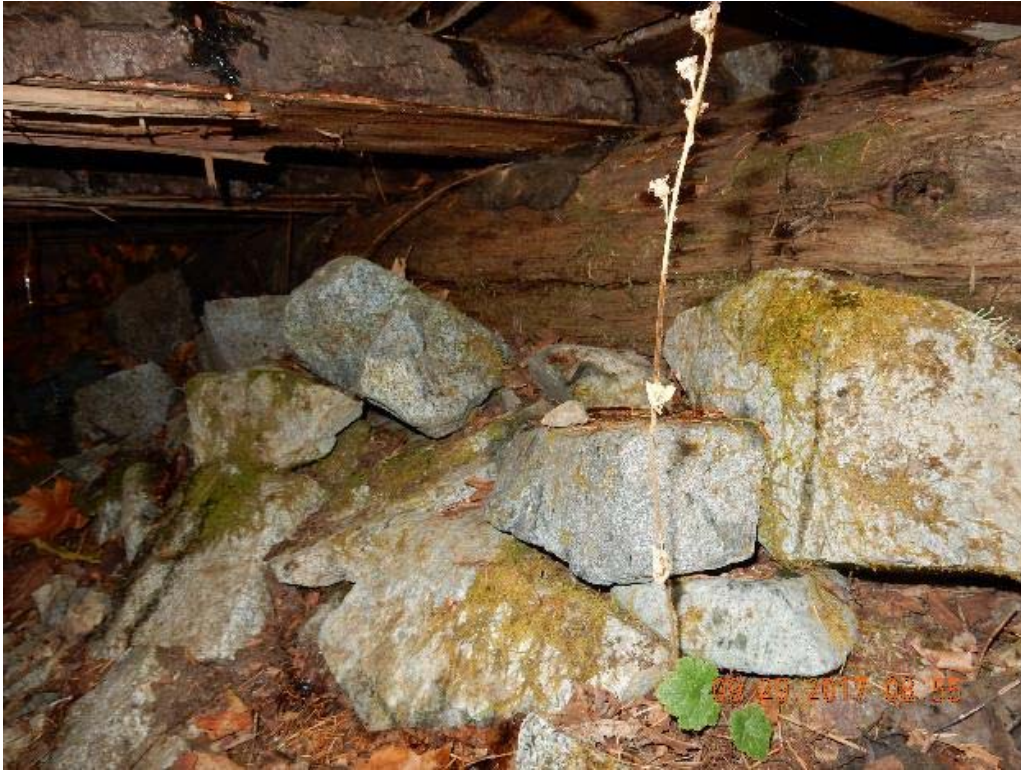

P07 – South abutment  
(DSCN9891.jpg)



P08 – North abutment  
(DSCN9892.jpg)



## Sunshine Coast 2017 Bridge Inspections



<b>Structure Name:</b>	Vine Brook	
<b>Parsons Waypoint #:</b>	290	
<b>Remaining Lifespan (Years):</b>	5	
<b>Replacement Cost:</b>	\$20,000	
<b>Georeference:</b>	N 49°40'57" W 123°57'50"	
<b>Deflection at Centre (mm):</b>	0	
<b>Weight Usage Restriction:</b>	NEGATIVE 2 people, 0 horses, 0 ATVs	
<b>Date Inspected:</b>	Sept. 29, 2017	
<b>Inspected By:</b>	Grant Waldie, P. Eng., PE Michael Li, EIT	
<b>Weather:</b>	15°C, rainy	
<b>Overall Rating of Bridge</b>		<b>Structure Description</b>
<b>CRITICAL</b>		17.8x1.5m beam bridge with timber deck.

Element	Rating	Comments	Maintenance Recommendations	Estimated Cost	Priority
<b>Primary Components</b>					
Embankments	5				
Foundations	5				
Abutments	5				
Beams, Girders	1	Logs are deteriorating	Replace main load carrying members of bridge	\$20,000	High
Deck	3	Deck is covered in moss	Remove moss to prevent further deterioration	\$1,000	Medium
<b>Secondary Components</b>					
Approaches	4				
Railings	4				
<b>Auxiliary Components</b>					
Slope Protection	4				
Signs	1	No load restriction sign present	This bridge passes strength capacity for more than 5 people, but we would not recommend any horses or ATVs on the bridge. From a deflection criteria, as laid out in the Canadian Timber Design Manual, this bridge requires NEGATIVE two people in order to pass. It is recommended that this bridge be highest on the SCRD's list of replacement bridges.		

## PROJECT

Sunshine Coast Trail Bridge Inspection Project

## DESIGNER

M.Li

## DATE

Oct 24th, 2017

## SUBJECT

Trail Bridge Load Rating

## CHECKER

G.Waldie

## DATE

Oct 25th, 2017

### Input Parameters

Bridge Name

Vine Brook

Number of Spans

1

Span Length (m)

17.8

Deck Width (mm)

1500

Deck Thickness (mm)

50

Number of Log Beams

2

Log Shape

Circular

Log Diameter (mm)

450

Single or Double Railing

Double

Timber Weight (kN/m<sup>3</sup>)

6.0 (Douglas Fir)

Elastic Modulus of Timber

9000 (CSA-O86 T5.3.1C)

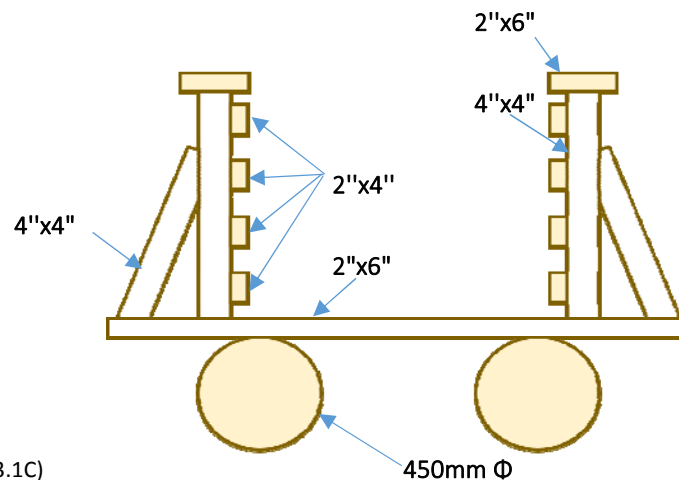

Cross Section

### Dead Load

Item	Railing	Deck	Log	Total
<b>w<sub>D</sub>(kN/m)</b>	0.50	0.45	1.91	2.86

Max. Bending Moment by DL  $M_D = wL^2/8 = 113.2 \text{ kN-m}$

Max. Deflection by DL  $\Delta_D = 5wL^4/384EI = 103.1 \text{ mm}$

### Capacity Check

Moment Resistance  $M_r = \Phi F_b S_k z_b K_L = 212.6 \text{ kN-m}$  (CSA-O86 5.5.4.1)

Load combination for ULS:  $M_r = 1.25M_D + 1.5M_L$

Max. Bending Moment by LL  $M_L = 47.4 \text{ kN-m}$

Max. Live Load  $w_L = 1.2 \text{ kN/m}$

### Deflection Check

Load combination for SLS:  $\Delta_{lim} = 1.0\Delta_D + 1.0\Delta_L$

Max. Deflection  $\Delta_{lim} = L/180 = 98.9 \text{ mm}$  (CSA-O86 4.5.2)

Max. Deflection by LL  $\Delta_L = -4.2 \text{ mm}$

Max. Live Load  $w_L = -0.1 \text{ kN/m}$

### Deck Area Check

Total Deck Area  $A = 26.7 \text{ m}^2$

### Summary

	Capacity Check	Deflection Check	Deck Area Check
<b>Person</b>	> -2 person	-2 person	> -2 person
<b>Horse</b>	> 0 horse	0 horse	> 0 horse
<b>ATV</b>	> 0 ATV	0 ATV	> 0 ATV

### Conclusion:

The capacity of this bridge is governed by deflection criteria. The maximum capacity of Vine Brook is: -2 person or 0 horse or 0 ATV.

# Vine Brook

## Sunshine Coast Trail Bridge Inspections – 2017



P01 – South approach  
(DSCN9844.jpg)



P02 – Overall decking  
(DSCN9846.jpg)

# Vine Brook

## Sunshine Coast Trail Bridge Inspections – 2017



P03 – West railing  
(DSCN9847.jpg)



P04 – East railing  
(DSCN9848.jpg)

# Vine Brook

## Sunshine Coast Trail Bridge Inspections – 2017



P05 – Downstream (looking west)  
(DSCN9850.jpg)



P06 – Upstream (looking east)  
(DSCN9851.jpg)

# Vine Brook

## Sunshine Coast Trail Bridge Inspections – 2017



P07 – Sign at northwest corner of the bridge says, “Look here before crossing the bridge with your quad, check bridge stringer” (DSCN9853.jpg)



P08 – North approach (DSCN9854.jpg)

# Vine Brook Sunshine Coast Trail Bridge Inspections – 2017



P09 – West side of the bridge  
(DSCN9855.jpg)



P10 – Northwest corner of the bridge, log is breaking apart  
(DSCN9856.jpg)

**Vine Brook**  
Sunshine Coast Trail Bridge Inspections – 2017



P11 – Northwest corner of the bridge, log is breaking apart  
(DSCN9859.jpg)



P12 – West side of the bridge (looking at middle pier)  
(DSCN9860.jpg)

**Vine Brook**  
Sunshine Coast Trail Bridge Inspections – 2017



P13 – Under side of the bridge  
(DSCN9863.jpg)



P14 – Middle pier  
(DSCN9864.jpg)

# Vine Brook

## Sunshine Coast Trail Bridge Inspections – 2017



P15 – East side of the bridge  
(DSCN9866.jpg)



P16 – North abutment  
(DSCN9867.jpg)

# **Appendix 2**

## **Zone 2 - Schedule B - Pender Bridge Assessment South**

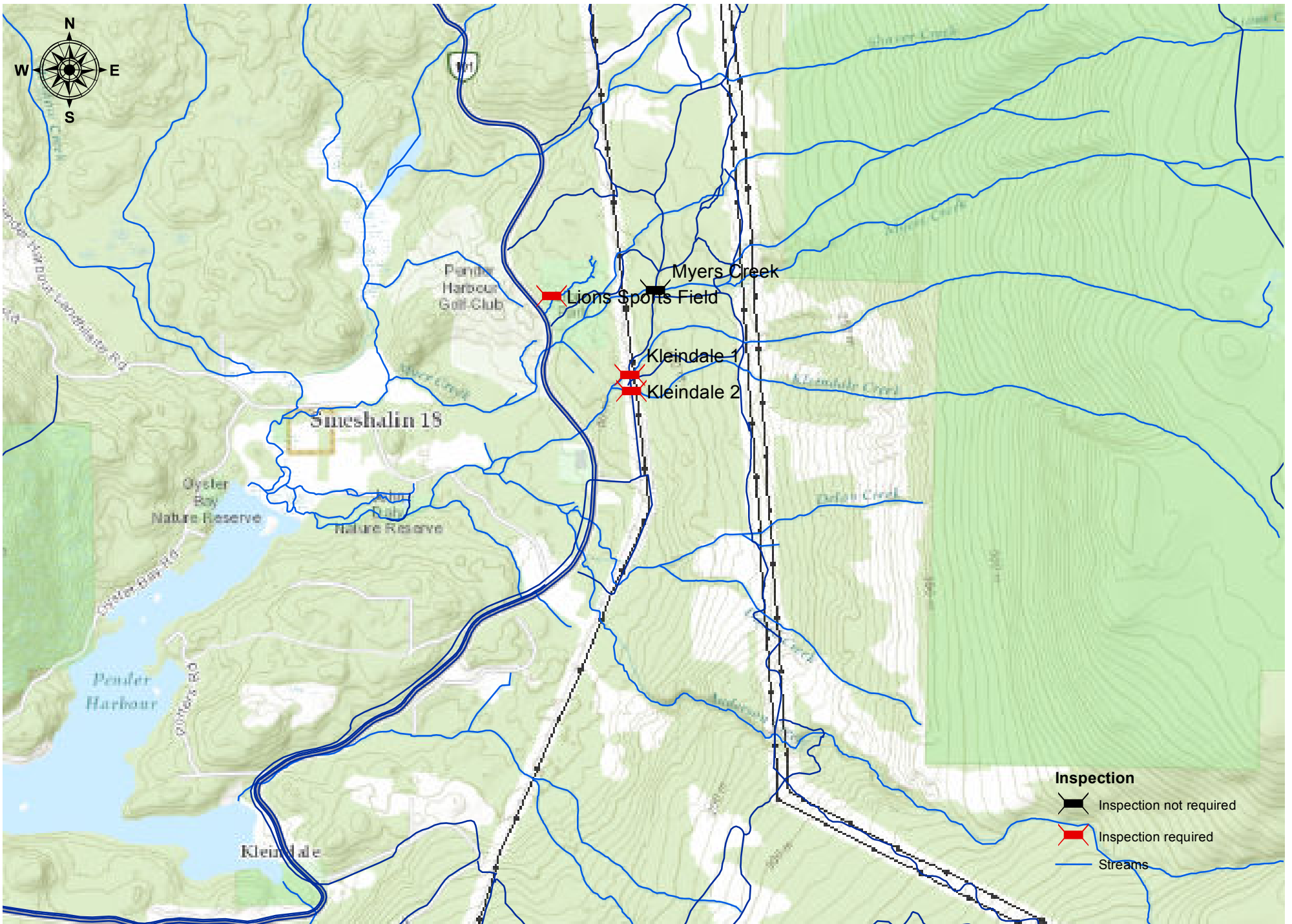

# Schedule B - Pender Bridge Assessment

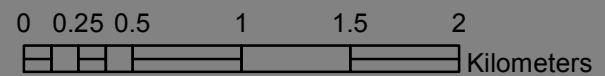



## Sunshine Coast 2017 Bridge Inspections



<b>Structure Name:</b> Kleindale 1	
<b>Parsons Waypoint #:</b> 315	
<b>Remaining Lifespan (Years):</b> 25	
<b>Replacement Cost:</b> \$20,000	
<b>Georeference:</b> N 49°38'42" W 123°57'52"	
<b>Deflection at Centre (mm):</b> 0	
<b>Weight Usage Restriction:</b> 25 people, 1 horse, 2 ATVs	
<b>Date Inspected:</b> Sept. 29, 2017	
<b>Inspected By:</b> Grant Waldie, P. Eng., PE Michael Li, EIT	
<b>Weather:</b> 15°C, rainy	
<b>Overall Rating of Bridge</b>	<b>Structure Description</b>
<b>VERY GOOD</b>	9.1x1.8m beam bridge with timber deck.

Element	Rating	Comments	Maintenance Recommendations	Estimated Cost	Priority
<b>Primary Components</b>					
Embankments	5				
Foundations	5				
Abutments	5				
Beams, Girders	5				
Deck	5				
<b>Secondary Components</b>					
Approaches	5				
Railings	5				
<b>Auxiliary Components</b>					
Slope Protection	5				
Signs	4	No load restriction sign present			

## PROJECT

Sunshine Coast Trail Bridge Inspection Project

## DESIGNER

M.Li

## DATE

Oct 24th, 2017

## SUBJECT

Trail Bridge Load Rating

## CHECKER

G.Waldie

## DATE

Oct 25th, 2017

### Input Parameters

Bridge Name	<b>Kleindale 1</b>
Number of Spans	1
Span Length (m)	9.1
Deck Width (mm)	1800
Deck Thickness (mm)	50
Number of Log Beams	2
Log Shape	Circular
Log Diameter (mm)	400
Single or Double Railing	Double
Timber Weight (kN/m <sup>3</sup> )	5.0 (Cedar)
Elastic Modulus of Timber	9000 (CSA-O86 T5.3.1C)

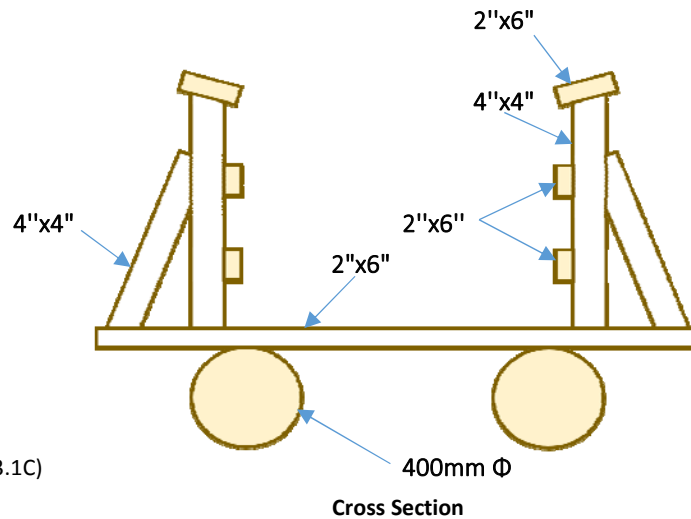

### Dead Load

Item	Railing	Deck	Log	Total
<b>w<sub>D</sub>(kN/m)</b>	0.50	0.45	1.26	2.21

Max. Bending Moment by DL  $M_D = wL^2/8 = 22.8 \text{ kN-m}$

Max. Deflection by DL  $\Delta_D = 5wL^4/384EI = 8.7 \text{ mm}$

### Capacity Check

Moment Resistance  $M_r = \Phi F_b S_{K_{zb}} K_L = 149.3 \text{ kN-m (CSA-O86 5.5.4.1)}$

Load combination for ULS:  $M_r = 1.25M_D + 1.5M_L$

Max. Bending Moment by LL  $M_L = 80.5 \text{ kN-m}$

Max. Live Load  $w_L = 7.8 \text{ kN/m}$

### Deflection Check

Load combination for SLS:  $\Delta_{lim} = 1.0\Delta_D + 1.0\Delta_L$

Max. Deflection  $\Delta_{lim} = L / 180 = 50.6 \text{ mm (CSA-O86 4.5.2)}$

Max. Deflection by LL  $\Delta_L = 41.8 \text{ mm}$

Max. Live Load  $w_L = 10.6 \text{ kN/m}$

### Deck Area Check

Total Deck Area  $A = 16.4 \text{ m}^2$

### Summary

	Capacity Check	Deflection Check	Deck Area Check
<b>Person</b>	> 25 people	> 25 people	> 25 people
<b>Horse</b>	> 1 horse	> 1 horse	> 1 horse
<b>ATV</b>	> 2 ATVs	> 2 ATVs	> 2 ATVs

### Conclusion:

The capacity of this bridge is governed by the bridge deck area. The maximum capacity of Kleindale 1 is: 25 people or 1 horse or 2 ATVs.

**Kleindale 1**  
Sunshine Coast Trail Bridge Inspections – 2017



P01 – North approach  
(DSCN9982.jpg)



P02 – Overall decking  
(DSCN9983.jpg)

**Kleindale 1**  
Sunshine Coast Trail Bridge Inspections – 2017



P03 – East railing  
(DSCN9984.jpg)



P04 – West railing  
(DSCN9985.jpg)

**Kleindale 1**  
Sunshine Coast Trail Bridge Inspections – 2017



P05 – Upstream (looking east)  
(DSCN9986.jpg)



P06 – Downstream (looking west)  
(DSCN9987.jpg)

# Kleindale 1

## Sunshine Coast Trail Bridge Inspections – 2017



P07 – South approach  
(DSCN9988.jpg)



P08 – East side of the bridge  
(DSCN9989.jpg)

# Kleindale 1

## Sunshine Coast Trail Bridge Inspections – 2017



P09 – East side of the bridge (detail view)  
(DSCN9990.jpg)



P10 – Under side of the bridge  
(DSCN9992.jpg)

**Kleindale 1**  
Sunshine Coast Trail Bridge Inspections – 2017



P11 – South abutment  
(DSCN9993.jpg)



P12 – Under side of the bridge (detail view)  
(DSCN9994.jpg)



## Sunshine Coast 2017 Bridge Inspections



<b>Structure Name:</b> Kleindale 2	
<b>Parsons Waypoint #:</b> 316	
<b>Remaining Lifespan (Years):</b> 25	
<b>Replacement Cost:</b> \$5,000	
<b>Georeference:</b> N 49°38'40" W 123°57'49"	
<b>Deflection at Centre (mm):</b> 0	
<b>Weight Usage Restriction:</b> 25 people, 1 horse, 2 ATVs	
<b>Date Inspected:</b> Sept. 29, 2017	
<b>Inspected By:</b> Grant Waldie, P. Eng., PE Michael Li, EIT	
<b>Weather:</b> 15°C, rainy	
<b>Overall Rating of Bridge</b>	<b>Structure Description</b>
<b>VERY GOOD</b>	12.1x1.8m beam bridge with timber deck.

Element	Rating	Comments	Maintenance Recommendations	Estimated Cost	Priority
<b>Primary Components</b>					
Embankments	5				
Foundations	5				
Abutments	5				
Beams, Girders	5				
Deck	5				
<b>Secondary Components</b>					
Approaches	5				
Railings	5				
<b>Auxiliary Components</b>					
Slope Protection	5				
Signs	4	No load restriction sign present			

## PROJECT

Sunshine Coast Trail Bridge Inspection Project

## DESIGNER

M.Li

## DATE

Oct 24th, 2017

## SUBJECT

Trail Bridge Load Rating

## CHECKER

G.Waldie

## DATE

Oct 25th, 2017

### Input Parameters

Bridge Name	<b>Kleindale 2</b>
Number of Spans	1
Span Length (m)	12.1
Deck Width (mm)	1800
Deck Thickness (mm)	50
Number of Log Beams	2
Log Shape	Circular
Log Diameter (mm)	400
Single or Double Railing	Double
Timber Weight (kN/m <sup>3</sup> )	5.0 (Cedar)
Elastic Modulus of Timber	9000 (CSA-O86 T5.3.1C)

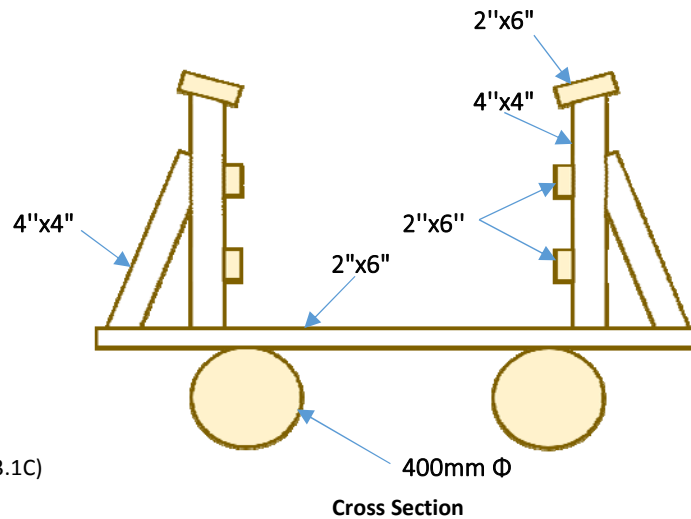

### Dead Load

Item	Railing	Deck	Log	Total
<b>w<sub>D</sub>(kN/m)</b>	0.50	0.45	1.26	2.21

$$\text{Max. Bending Moment by DL } M_D = wL^2/8 = 40.4 \text{ kN-m}$$

$$\text{Max. Deflection by DL } \Delta_D = 5wL^4/384EI = 27.2 \text{ mm}$$

### Capacity Check

$$\text{Moment Resistance } M_r = \Phi F_b S_k z_b K_L = 149.3 \text{ kN-m (CSA-O86 5.5.4.1)}$$

$$\text{Load combination for ULS: } M_r = 1.25M_D + 1.5M_L$$

$$\text{Max. Bending Moment by LL } M_L = 65.9 \text{ kN-m}$$

$$\text{Max. Live Load } w_L = 3.6 \text{ kN/m}$$

### Deflection Check

$$\text{Load combination for SLS: } \Delta_{lim} = 1.0\Delta_D + 1.0\Delta_L$$

$$\text{Max. Deflection } \Delta_{lim} = L / 180 = 67.2 \text{ mm (CSA-O86 4.5.2)}$$

$$\text{Max. Deflection by LL } \Delta_L = 40.0 \text{ mm}$$

$$\text{Max. Live Load } w_L = 3.2 \text{ kN/m}$$

### Deck Area Check

$$\text{Total Deck Area } A = 21.8 \text{ m}^2$$

### Summary

	Capacity Check	Deflection Check	Deck Area Check
<b>Person</b>	> 25 people	> 25 people	> 25 people
<b>Horse</b>	> 1 horse	> 1 horse	> 1 horse
<b>ATV</b>	> 2 ATVs	> 2 ATVs	> 2 ATVs

### Conclusion:

The capacity of this bridge is governed by the bridge deck area. The maximum capacity of Kleindale 2 is: 25 people or 1 horse or 2 ATVs.

## Kleindale 2

### Sunshine Coast Trail Bridge Inspections – 2017



P01 – North approach  
(DSCN9998.jpg)



P02 – Overall decking  
(DSCN9999.jpg)

## Kleindale 2 Sunshine Coast Trail Bridge Inspections – 2017



P03 – East railing  
(DSCN0001.jpg)



P04 – West railing  
(DSCN0002.jpg)

**Kleindale 2**  
Sunshine Coast Trail Bridge Inspections – 2017



P05 – Downstream (looking west)  
(DSCN0003.jpg)



P06 – Upstream (looking east)  
(DSCN0004.jpg)

## Kleindale 2

### Sunshine Coast Trail Bridge Inspections – 2017



P07 – South approach  
(DSCN0005.jpg)



P08 – East side of the bridge  
(DSCN0006.jpg)

**Kleindale 2**  
Sunshine Coast Trail Bridge Inspections – 2017



P09 – Under side of the bridge (looking north)  
(DSCN0007.jpg)



P10 – South abutment  
(DSCN0008.jpg)



## Sunshine Coast 2017 Bridge Inspections



<b>Structure Name:</b> Lion's Sport Field	
<b>Parsons Waypoint #:</b> 313	
<b>Remaining Lifespan (Years):</b> 25	
<b>Replacement Cost:</b> \$30,000	
<b>Georeference:</b> N 49°38'54" W 123°58'08"	
<b>Deflection at Centre (mm):</b> 0	
<b>Weight Usage Restriction:</b> SEE LOAD RATING REPORT IN APPENDIX	
<b>Date Inspected:</b> Sept. 29, 2017	
<b>Inspected By:</b> Grant Waldie, P. Eng., PE Michael Li, EIT	
<b>Weather:</b> 15°C, rainy	
<b>Overall Rating of Bridge</b>	<b>Structure Description</b>
<b>GOOD</b>	13.8x3.8m steel box girder bridge.

Element	Rating	Comments	Maintenance Recommendations	Estimated Cost	Priority
<b>Primary Components</b>					
Embankments	5				
Foundations	5				
Abutments	5				
Beams, Girders	5				
Deck	5				
Coatings	3	Paint system is starting to deteriorate	Repaint bridge	\$5,000	Low
<b>Secondary Components</b>					
Curbs	5				
Approaches	5				
<b>Auxiliary Components</b>					
Slope Protection	5				
Signs	-	No load restriction sign present	See load rating report in appendix		

# Lion's Sport Field

## Sunshine Coast Trail Bridge Inspections – 2017



P01 – North approach  
(DSCN9953.jpg)



P02 – Overall decking  
(DSCN9954.jpg)

# Lion's Sport Field

## Sunshine Coast Trail Bridge Inspections – 2017



P03 – East curb  
(DSCN9955.jpg)



P04 – West curb  
(DSCN9956.jpg)

# Lion's Sport Field

## Sunshine Coast Trail Bridge Inspections – 2017



P05 – South end of the bridge  
(DSCN9958.jpg)



P06 – South approach  
(DSCN9960.jpg)

# Lion's Sport Field

## Sunshine Coast Trail Bridge Inspections – 2017



P07 – Side view of the main C-Channel  
(DSCN9961.jpg)

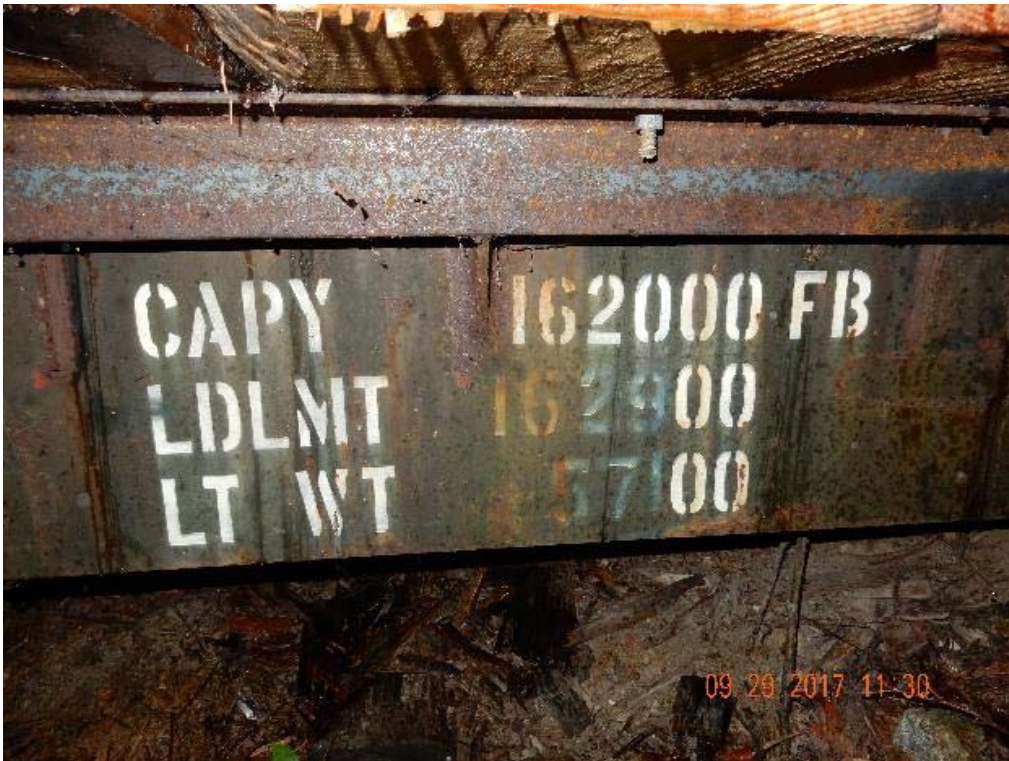

P08 – Side view of the main C-Channel  
(DSCN9962.jpg)

# Lion's Sport Field

## Sunshine Coast Trail Bridge Inspections – 2017

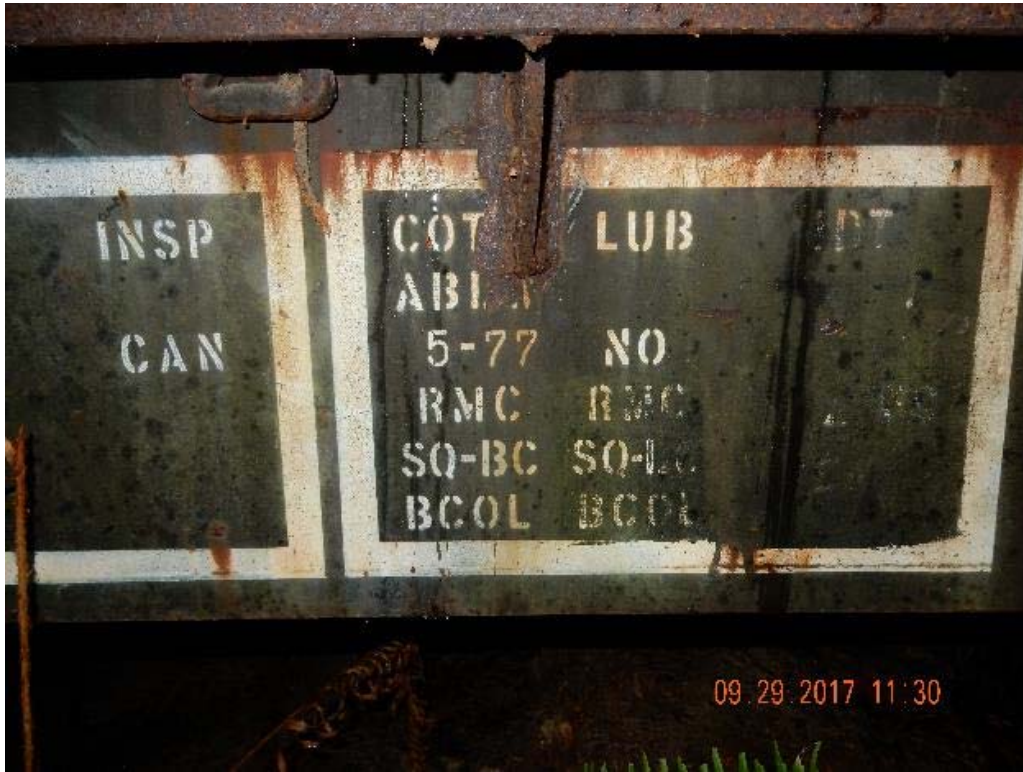

P09 – Side view of the main C-Channel  
(DSCN9963.jpg)



P10 – East side of the bridge  
(DSCN9965.jpg)

**Lion's Sport Field**  
Sunshine Coast Trail Bridge Inspections – 2017



P11 – West side of the bridge, looking at triangular diaphragm  
(DSCN9966.jpg)



P12 – Under side of the main box girder  
(DSCN9967.jpg)

**Lion's Sport Field**  
Sunshine Coast Trail Bridge Inspections – 2017



P13 – East side of the bridge, looking at triangular diaphragm (DSCN9968.jpg)



P14 – East side of the bridge, looking at three floor beams in between diaphragms (DSCN9969.jpg)

**Lion's Sport Field**  
Sunshine Coast Trail Bridge Inspections – 2017



P15 – East side of the bridge, looking at south abutment  
(DSCN9970.jpg)



P16 – Detail view of floor beam  
(DSCN9973.jpg)

# Lion's Sport Field

## Sunshine Coast Trail Bridge Inspections – 2017



P17 – Looking inside of the main box girder  
(DSCN9975.jpg)



P18 – Metal sign on the side of the bridge  
(DSCN9976.jpg)

**Lion's Sport Field**  
Sunshine Coast Trail Bridge Inspections – 2017



P19 – West side of the bridge (looking at south abutment)  
(DSCN9978.jpg)



## Sunshine Coast 2017 Bridge Inspections



<b>Structure Name:</b> Myers Creek	
<b>Parsons Waypoint #:</b> 317	
<b>Remaining Lifespan (Years):</b> 25	
<b>Replacement Cost:</b> \$20,000	
<b>Georeference:</b> N 49°38'54" W 123°57'45"	
<b>Deflection at Centre (mm):</b> 0	
<b>Weight Usage Restriction:</b> 25 people, 1 horse, 2 ATVs	
<b>Date Inspected:</b> Sept. 29, 2017	
<b>Inspected By:</b> Grant Waldie, P. Eng., PE Michael Li, EIT	
<b>Weather:</b> 15°C, rainy	
<b>Overall Rating of Bridge</b>	<b>Structure Description</b>
<b>VERY GOOD</b>	18.4x1.8m beam bridge with timber deck.

Element	Rating	Comments	Maintenance Recommendations	Estimated Cost	Priority
<b>Primary Components</b>					
Embankments	5				
Foundations	5				
Abutments	5				
Beams, Girders	5				
Deck	5				
<b>Secondary Components</b>					
Approaches	5				
Railings	5				
<b>Auxiliary Components</b>					
Slope Protection	5				
Signs	5	Bridge load rating meets strength and deflection criteria and it is OK to keep the current sign on the bridge.			

## PROJECT

Sunshine Coast Trail Bridge Inspection Project

## DESIGNER

M.Li

## DATE

Oct 24th, 2017

## SUBJECT

Trail Bridge Load Rating

## CHECKER

G.Waldie

## DATE

Oct 25th, 2017

### Input Parameters

Bridge Name	<b>Myers Creek</b>
Number of Spans	1
Span Length (m)	<b>18.4</b>
Deck Width (mm)	<b>1800</b>
Deck Thickness (mm)	<b>50</b>
Number of Log Beams	3
Log Shape	Circular
Log Diameter (mm)	<b>500</b>
Single or Double Railing	Double
Timber Weight (kN/m <sup>3</sup> )	<b>5.0</b> (Cedar)
Elastic Modulus of Timber	<b>9000</b> (CSA-O86 T5.3.1C)

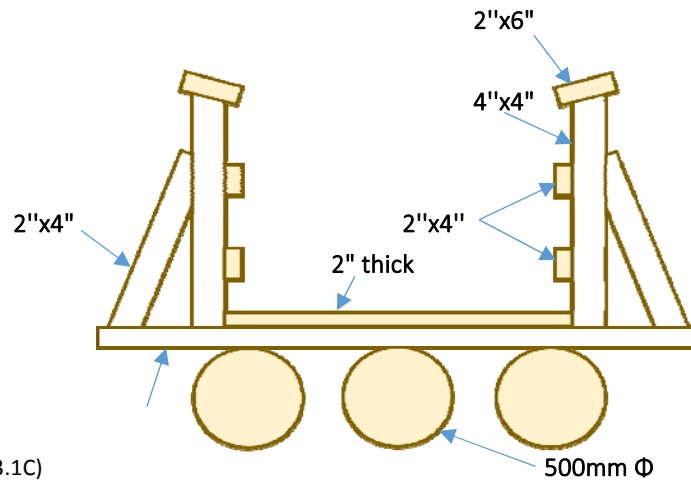

Cross Section

### Dead Load

Item	Railing	Deck	Log	Total
<b>w<sub>D</sub>(kN/m)</b>	0.50	0.45	2.95	3.90

Max. Bending Moment by DL  $M_D = wL^2/8 = 164.8 \text{ kN-m}$

Max. Deflection by DL  $\Delta_D = 5wL^4/384EI = 70.2 \text{ mm}$

### Capacity Check

Moment Resistance  $M_r = \Phi F_b S K_{zb} K_L = 437.4 \text{ kN-m}$  (CSA-O86 5.5.4.1)

Load combination for ULS:  $M_r = 1.25M_D + 1.5M_L$

Max. Bending Moment by LL  $M_L = 154.2 \text{ kN-m}$

Max. Live Load  $w_L = 3.6 \text{ kN/m}$

### Deflection Check

Load combination for SLS:  $\Delta_{lim} = 1.0\Delta_D + 1.0\Delta_L$

Max. Deflection  $\Delta_{lim} = L/180 = 102.2 \text{ mm}$  (CSA-O86 4.5.2)

Max. Deflection by LL  $\Delta_L = 32.0 \text{ mm}$

Max. Live Load  $w_L = 1.8 \text{ kN/m}$

### Deck Area Check

Total Deck Area  $A = 33.1 \text{ m}^2$

### Summary

	Capacity Check	Deflection Check	Deck Area Check
<b>Person</b>	> 25 people	> 25 people	> 25 people
<b>Horse</b>	> 1 horse	> 1 horse	> 1 horse
<b>ATV</b>	> 2 ATVs	> 2 ATVs	> 2 ATVs

### Conclusion:

The capacity of this bridge is governed by the bridge deck area. The maximum capacity of Myers Creek is: 25 people or 1 horse or 2 ATVs.

# Myers Creek Sunshine Coast Trail Bridge Inspections – 2017



P01 – South approach  
(DSCN0011.jpg)



P02 – South end of the bridge  
(DSCN0012.jpg)

# Myers Creek Sunshine Coast Trail Bridge Inspections – 2017



P03 – Loading rating sign at the southeast corner of the bridge  
(DSCN0014. jpg)



P04 – West railing  
(DSCN0019.jpg)

# Myers Creek Sunshine Coast Trail Bridge Inspections – 2017



P05 – East railing  
(DSCN0020.jpg)



P06 – Upstream (looking east)  
(DSCN0021.jpg)

# Myers Creek

## Sunshine Coast Trail Bridge Inspections – 2017



P07 – Downstream (looking west)  
(DSCN0022.jpg)



P08 – North approach  
(DSCN0023.jpg)

# Myers Creek Sunshine Coast Trail Bridge Inspections – 2017



P09 – East side of the bridge  
(DSCN0025.jpg)



P10 – North embankment  
(DSCN00026.jpg)

# Myers Creek Sunshine Coast Trail Bridge Inspections – 2017



P11 – South embankment  
(DSCN0027.jpg)



P12 – West side of the bridge  
(DSCN0029.jpg)

# **Appendix 3**

## **Zone 3 - Schedule B - Area B Bridge Assessment**

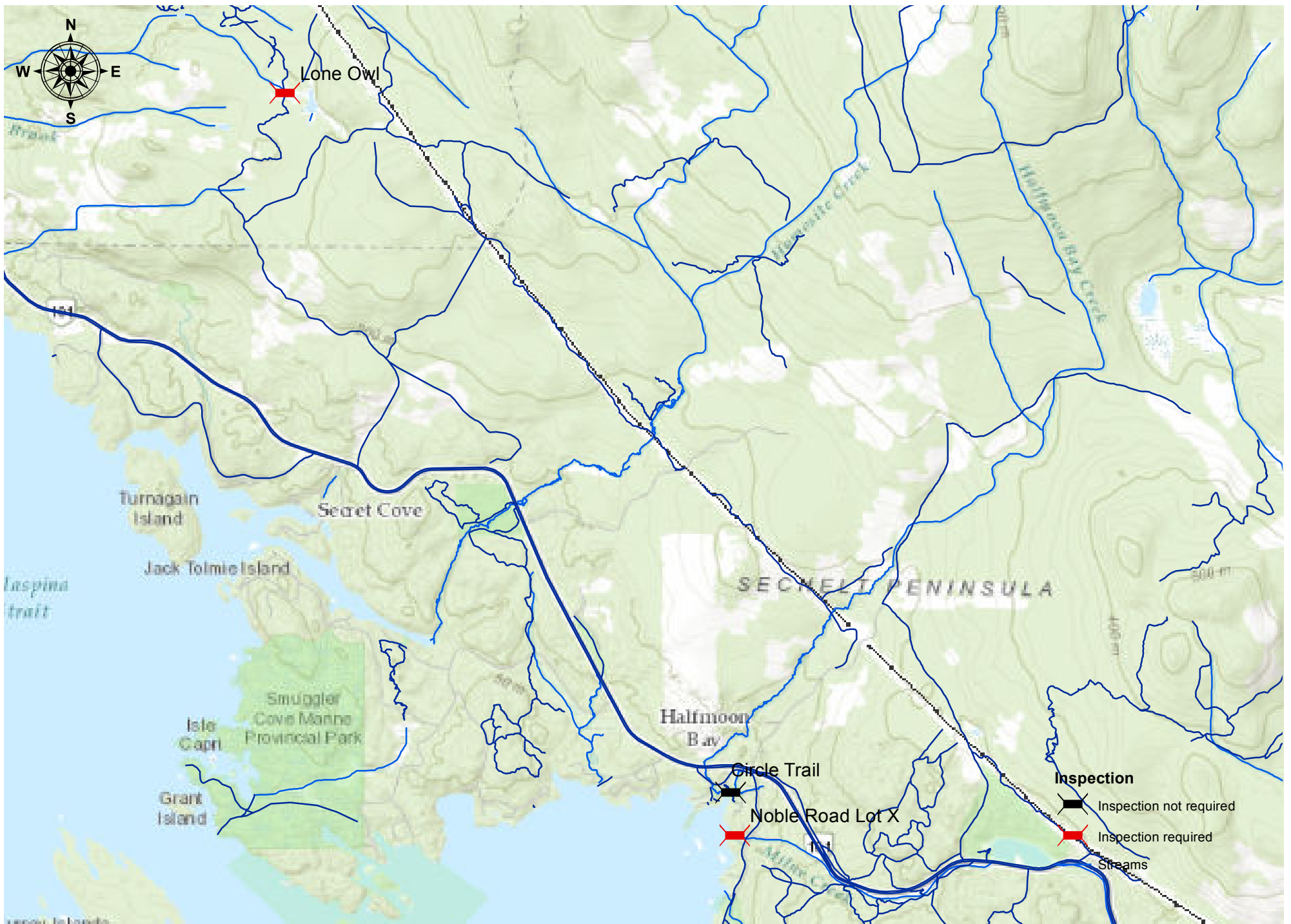

# Schedule B - Area B Bridge Assessment

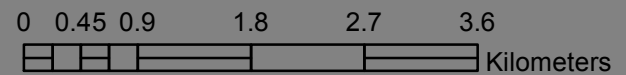



## Sunshine Coast 2017 Bridge Inspections



<b>Structure Name:</b> Circle Trail	
<b>Parsons Waypoint #:</b> 345	
<b>Remaining Lifespan (Years):</b> 40	
<b>Replacement Cost:</b> \$20,000	
<b>Georeference:</b> N 49°30'44" W 123°54'28"	
<b>Deflection at Centre (mm):</b> 0	
<b>Weight Usage Restriction:</b> 23 people, 1 horse, 2 ATVs	
<b>Date Inspected:</b> Sept. 29, 2017	
<b>Inspected By:</b> Grant Waldie, P. Eng., PE Michael Li, EIT	
<b>Weather:</b> 15°C, rainy	
<b>Overall Rating of Bridge</b>	<b>Structure Description</b>
<b>VERY GOOD</b>	7.3x1.6m aluminum bridge.

Element	Rating	Comments	Maintenance Recommendations	Estimated Cost	Priority
<b>Primary Components</b>					
Embankments	3	Erosion noticed at north embankment	Monitor erosion	N/A	Medium
Foundations	5				
Abutments	5				
Floor Beams	5				
Trusses	5				
Deck	5				
Coatings	5				
<b>Secondary Components</b>					
Bearing Seats	5				
Approaches	4	Old bridge is still on site (photo 16)	Remove old bridge	\$1,000	Medium
Railings	5				
<b>Auxiliary Components</b>					
Slope Protection	5				
Signs	4	No load restriction sign present			

## PROJECT

Sunshine Coast Trail Bridge Inspection Project

## DESIGNER

M.Li

## DATE

Oct 24th, 2017

## SUBJECT

Trail Bridge Load Rating

## CHECKER

G.Waldie

## DATE

Oct 25th, 2017

## Input Parameters

Bridge Name	Circle Trail	
Number of Spans	1	
Span Length (m)	7.3	
Deck Width (mm)	1600	
Deck Thickness (mm)	5	
Critical Section	HSS	
Section Width and Height (mm)	75	& 75
Section Wall Thickness (mm)	5	
Aluminum Weight (kN/m <sup>3</sup> )	27.0	
Elastic Modulus of Aluminum (MPa)	70000	

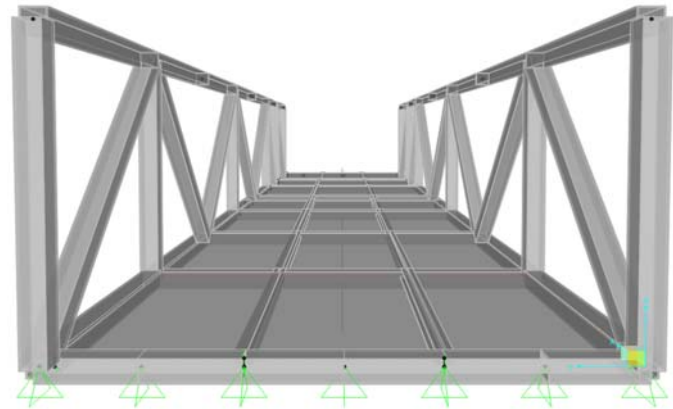

SAP2000 Model

## Capacity Check

\*Based on FE model analysis, the critical capacity is the bending capacity of the floor beam at mid-span

Moment Resistance	$M_r$	=	6.647 kN-m	$(\Phi_y F_y S_x)$
Load combination for ULS:	$M_r = 1.25M_D + 1.7M_L$			
Max. Bending Moment by DL	$M_D$	=	0.04 kN-m	(FE model analysis result)
Max Bending Moment by 4kN/m <sup>2</sup>	$M_4$	=	0.8 kN-m	(FE model analysis result)
Max. Bending Moment Allowed by LL	$M_L$	=	3.9 kN-m	$(M_r - M_D * 1.25) / 1.7$
Max. Allowed Total Live Load	$w_L$	=	19 kN/m <sup>2</sup>	$(M_L * 4 / M_4)$

## Deflection Check

Load combination for SLS:  $\Delta_{lim} = 1.0\Delta_D + 1.0\Delta_L$

Max. Deflection	$\Delta_{lim}$	=	41 mm	$(L / 180)$
Max. Deflection by DL	$\Delta_D$	=	0.2 mm	(FE model analysis result)
Max. Deflection by 4kN/m <sup>2</sup>	$\Delta_4$	=	3.6 mm	(FE model analysis result)
Max. Deflection Allowed by LL	$\Delta_L$	=	40 mm	$(\Delta_{lim} - \Delta_D)$
Max. Allowed Total Live Load	$w_L$	=	45 kN/m <sup>2</sup>	$(\Delta_L * 4 / \Delta_4)$

## Deck Area Check

Total Deck Area	A	=	11.7 m <sup>2</sup>
-----------------	---	---	---------------------

## Summary

	Capacity Check	Deflection Check	Deck Area Check
Person	> 23 people	> 23 people	23 people
Horse	> 1 horse	> 1 horse	1 horse
ATV	> 2 ATVs	> 2 ATVs	> 2 ATVs

## Conclusion:

The capacity of this bridge is governed by the bridge deck area. The maximum capacity of Circle Trail is: 23 people or 1 horse or 2 ATVs.

# Circle Trail

## Sunshine Coast Trail Bridge Inspections – 2017



P01 – North approach  
(DSCN0064.jpg)



P02 – West side of the bridge  
(DSCN0065.jpg)

# Circle Trail

## Sunshine Coast Trail Bridge Inspections – 2017



P03 – East side of the bridge  
(DSCN0066.jpg)



P04 – Overall decking  
(DSCN0067.jpg)

**Circle Trail**  
Sunshine Coast Trail Bridge Inspections – 2017



P05 – East railing  
(DSCN0068.jpg)



P06 – West railing  
(DSCN0069.jpg)

# Circle Trail

## Sunshine Coast Trail Bridge Inspections – 2017



P07 – Downstream (looking west)  
(DSCN0070.jpg)

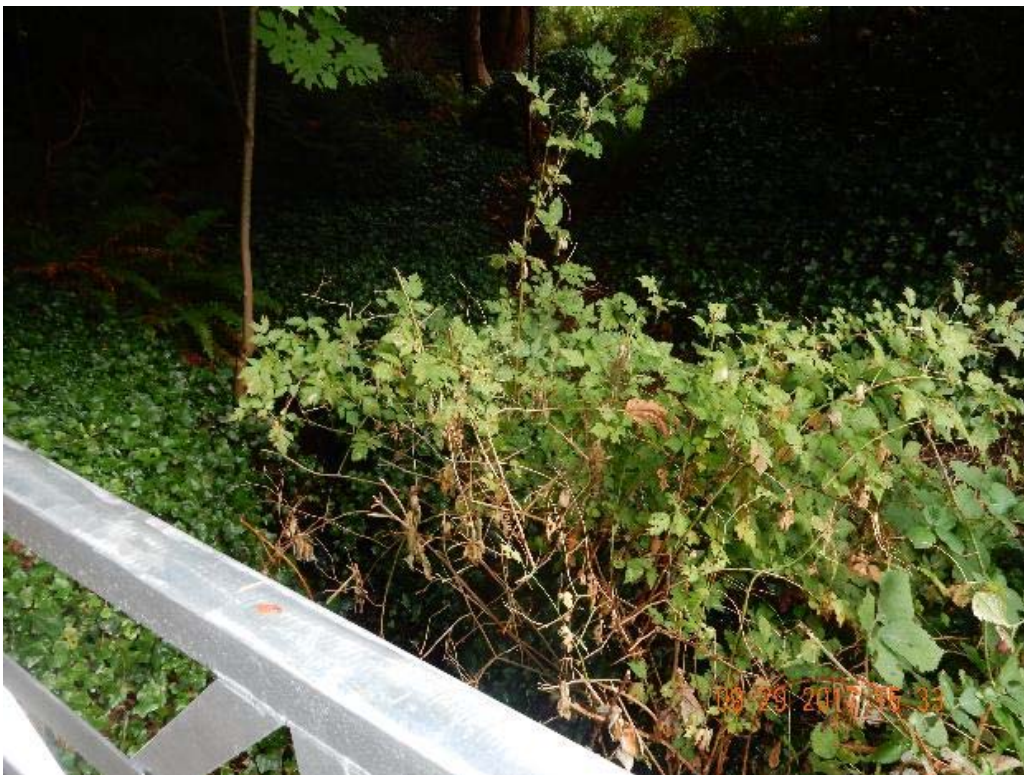

P08 – Upstream (looking east)  
(DSCN0071.jpg)

# Circle Trail

## Sunshine Coast Trail Bridge Inspections – 2017



P09 – South approach  
(DSCN0072.jpg)



P10 – West side of the bridge  
(DSCN0073.jpg)

# Circle Trail

## Sunshine Coast Trail Bridge Inspections – 2017



P11 – North embankment, erosion was noticed, needs to be monitored (DSCN0075.jpg)



P12 – South embankment (DSCN0076.jpg)

**Circle Trail**  
Sunshine Coast Trail Bridge Inspections – 2017



P13 – Under side of the bridge  
(DSCN0077.jpg)



P14 – Under side of the bridge  
(DSCN0078.jpg)

# Circle Trail

## Sunshine Coast Trail Bridge Inspections – 2017



P15 – Detail view of the stringer  
(DSCN0080.jpg)



P16 – Old bridge, suggest taking away  
(DSCN0082.jpg)



## Sunshine Coast 2017 Bridge Inspections



<b>Structure Name:</b> Lone Owl	
<b>Parsons Waypoint #:</b> 341	
<b>Remaining Lifespan (Years):</b> 25	
<b>Replacement Cost:</b> \$20,000	
<b>Georeference:</b> N 49°33'44" W 123°57'30"	
<b>Deflection at Centre (mm):</b> 0	
<b>Weight Usage Restriction:</b> 24 people, 1 horse, 2 ATVs	
<b>Date Inspected:</b> Sept. 29, 2017	
<b>Inspected By:</b> Grant Waldie, P. Eng., PE Michael Li, EIT	
<b>Weather:</b> 15°C, rainy	
<b>Overall Rating of Bridge</b>	<b>Structure Description</b>
<b>VERY GOOD</b>	16.6x1.75m beam bridge with timber deck.

Element	Rating	Comments	Maintenance Recommendations	Estimated Cost	Priority
<b>Primary Components</b>					
Embankments	5				
Foundations	5				
Abutments	5				
Piers	5				
Beams, Girders	5				
Deck	5				
<b>Secondary Components</b>					
Approaches	5				
Railings	5				
<b>Auxiliary Components</b>					
Slope Protection	5				
Signs	2	No load restriction sign present	Install load restriction sign	\$1,000	High

## PROJECT

Sunshine Coast Trail Bridge Inspection Project

## DESIGNER

M.Li

## DATE

Oct 24th, 2017

## SUBJECT

Trail Bridge Load Rating

## CHECKER

G.Waldie

## DATE

Oct 25th, 2017

### Input Parameters

Bridge Name	Lone Owl
Number of Spans	1
Span Length (m)	10.6
Deck Width (mm)	1750
Deck Thickness (mm)	50
Number of Log Beams	3
Log Shape	Circular
Log Diameter (mm)	300
Single or Double Railing	Double
Timber Weight (kN/m <sup>3</sup> )	5.0 (Cedar)
Elastic Modulus of Timber	9000 (CSA-O86 T5.3.1C)

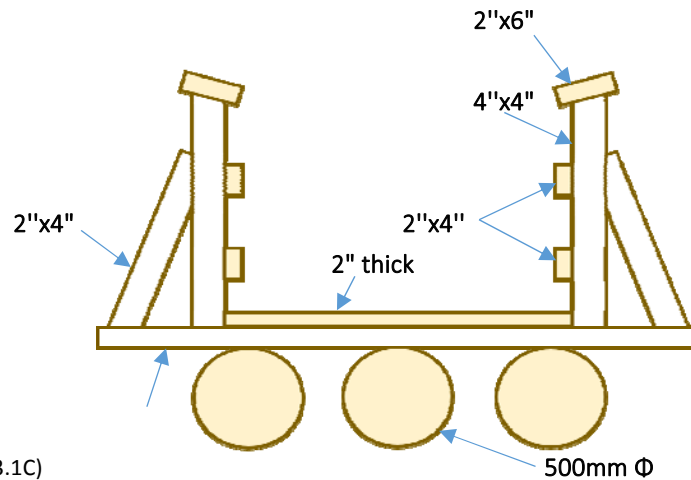

Cross Section

### Dead Load

Item	Railing	Deck	Log	Total
$w_D$ (kN/m)	0.50	0.44	1.06	2.00

Max. Bending Moment by DL  $M_D = wL^2/8 = 28.1$  kN-m

Max. Deflection by DL  $\Delta_D = 5wL^4/384EI = 30.6$  mm

### Capacity Check

Moment Resistance  $M_r = \Phi F_b S K_{zb} K_L = 94.47$  kN-m (CSA-O86 5.5.4.1)

Load combination for ULS:  $M_r = 1.25M_D + 1.5M_L$

Max. Bending Moment by LL  $M_L = 39.6$  kN-m

Max. Live Load  $w_L = 2.8$  kN/m

### Deflection Check

Load combination for SLS:  $\Delta_{lim} = 1.0\Delta_D + 1.0\Delta_L$

Max. Deflection  $\Delta_{lim} = L/180 = 58.9$  mm (CSA-O86 4.5.2)

Max. Deflection by LL  $\Delta_L = 28.3$  mm

Max. Live Load  $w_L = 1.8$  kN/m

### Deck Area Check

Total Deck Area  $A = 18.6$  m<sup>2</sup>

### Summary

	Capacity Check	Deflection Check	Deck Area Check
Person	> 24 people	24 people	> 24 people
Horse	> 1 horse	> 1 horse	> 1 horse
ATV	> 2 ATVs	> 2 ATVs	> 2 ATVs

### Conclusion:

The capacity of this bridge is governed by deflection criteria. The maximum capacity of Lone Owl is: 24 people or 1 horse or 2 ATVs.

# Lone Owl

## Sunshine Coast Trail Bridge Inspections – 2017



P01 – South approach  
(DSCN0031.jpg)



P02 – Overall decking  
(DSCN0032.jpg)

**Lone Owl**  
Sunshine Coast Trail Bridge Inspections – 2017



P03 – West railing  
(DSCN0033.jpg)



P04 – East railing  
(DSCN0034.jpg)